

# *A Practical Guide to 'Free Energy' Devices*

Part D7: Last updated: 30th July 2006

Author: Patrick J. Kelly

## **6. There are several other systems which are not likely to produce practical devices**

Faraday's Homopolar system, Tesla Coil, Lutec, Mini-Romag (JLN), Cold Fusion, etc.

The devices mentioned in this section are not inferior in any way. It is merely that there is so little specific information available on them, or such exotic materials used, that there is little likelihood of their reaching widespread use.

**The Homopolar or N-Machine.** This device was the brainchild of Michael Faraday and has an intriguing method of operation and a remarkably large output.



The principle of operation is incredibly simple:

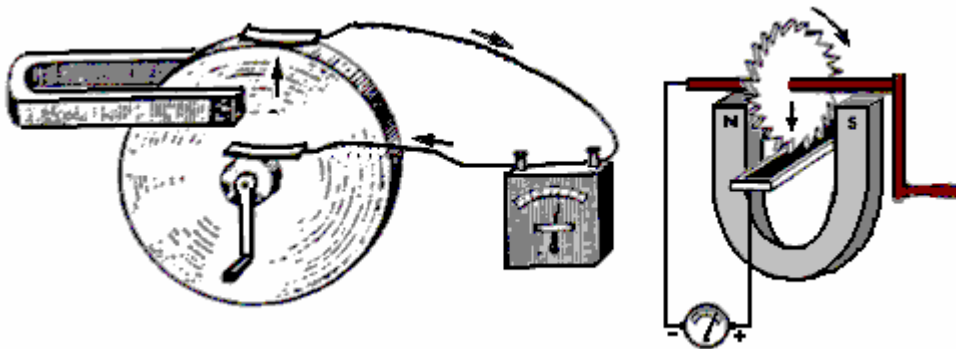

If a copper disc is rotated in a magnetic field, then power is developed between the shaft and the outer edge (or any intermediate position). It was then found that the device will still operate even if the magnet is attached to the copper disc and rotates with it - not something which is intuitively obvious. The power output is tremendous with the capability of extracting 1000 Amps but at a low voltage of less than 1 Volt. The power take-off can be from one face of the disc near the shaft rather than having to have a copper shaft integral with the copper disc.

This looks like a very viable starting point to develop a device which can run itself and provide useful additional output, since a motor to rotate the disc will not require anything remotely like 1000A to drive it.

The snag is, it is very difficult to provide reliable sliding contacts capable of handling large currents for extended periods of time. The second picture above shows the disc with its outer edge immersed in a bath of mercury. This is sufficient for a brief demonstration at low power but not realistic for a serious working device.

It might just be possible to get a reasonable working device by accepting that the current output is not going to be anything like 1000A. Long-life brushes could be made from solid copper bar and spring-loaded against the copper disc in matching pairs so that the brush thrusts oppose each other and so do not generate a sideways load. These could be made in multiple sets for each disc, say four or eight per disc, so that the effective electrical resistance between the brushes and the disc is reduced and the possible current draw increased.

Similar multiple brushes could be applied to the central shaft cylinder. Multiple discs could then be mounted on a non-conducting, non-magnetic shaft and their brushes wired in series as shown, to raise the output voltage:

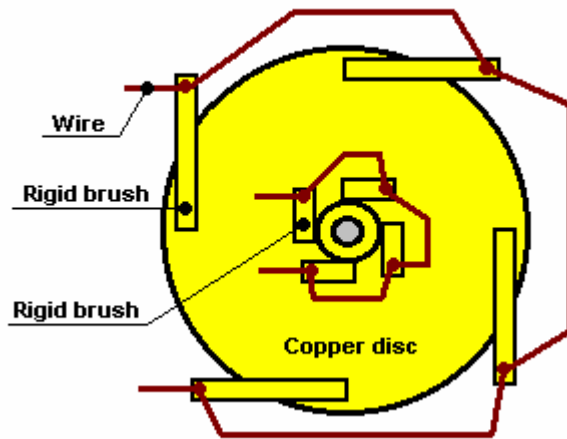
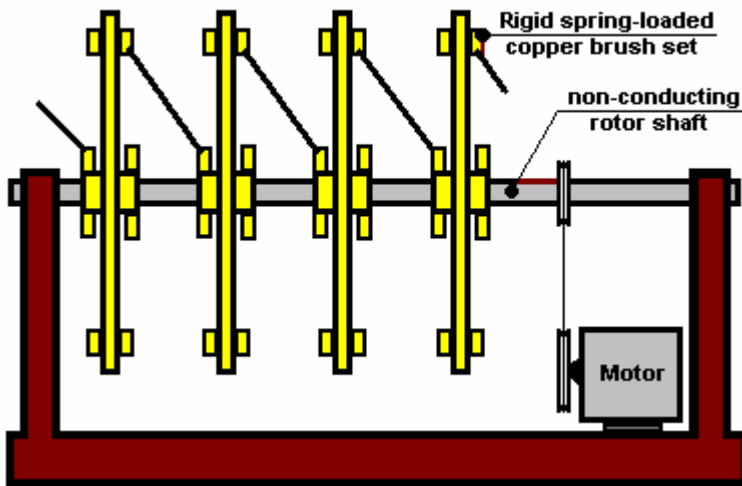

**Tesla:** Nikola Tesla produced so many startling ground-breaking inventions that it is difficult to know what to say about him, apart from the obvious comment that he was a genius. Tesla Coils are one of several of his inventions which pick up zero-point energy when they operate, very much in the same way as Ed Gray senior's motor circuit does. If you are interested in building a practical Tesla Coil, then it would most definitely be worth your while getting a copy of the excellent booklet "Tesla Coil" by George Trinkaus, (High Voltage Press, P.O. Box 1525, Portland, OR 97207, website: <http://www.teslapress.com>). This book is packed with the practical details needed when constructing a safe and reliable Tesla Coil.

Essentially, a Tesla Coil develops a very high voltage, stored in a very large high-voltage capacitor, which is then discharged in the form of a bolt of lightning. The power in the lightning bolt exceeds the power input used to create the bolt. The basic circuit is:

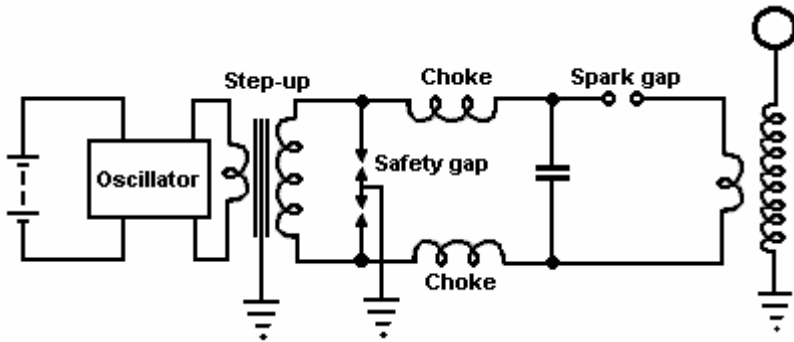

Which, when you examine it carefully, is very close indeed to the circuit used so successfully by Edwin Gray snr. who trapped the spark discharge and fed it into the drive coils of his motor and into the battery under charge. So, perhaps it is unfair to include the Tesla Coil in this section when Ed Gray appears to have utilised it. For our purposes, we would substitute a step-down transformer for the step-up output transformer shown. This would bring the output voltage down to a reasonable level, ready to be passed through a full-wave bridge rectifier and used to perform useful work.

**The Lutec Motor.** The Lutec motor has been described by some as a con trick. It is by no means certain that this is true. Either way, there appears to have been little or no development of it in the last few years, so the information on it is presented here just for your information.

The people presenting the 'Lutec' motor, claim to have US patent 09/831160 granted in 1999. I have not managed to locate any details on this patent although most US patents are reasonably easy to examine. They claim that this self-powered motor has a 1 kW DC output and their objective is to market it commercially. They make claims for magnet life of 1200 years which, to me, seems excessive, to put it mildly, eleven years being suggested elsewhere for permanent magnet life. As they have been covered by patent for several years, my question is: why have they not sold any units? Where are the satisfied customers with their testimonials?

You can check on the current situation with them at [www.lutec.com.au](http://www.lutec.com.au) where they say that the unit will be available for sale at the end of 2005, size 4.5' x 2', weight 120 Kg. It is interesting that only a few months from supposed production sales, they have no idea of what the price might be. Sales are only to Australia and New Zealand with no distribution outlets anywhere else in the world. I would be delighted to be proved over-pessimistic and have Lutecs sold and installed 'down under' but I will not hold my breath until then. This is what it looks like:



The method of operation is not described in any detail. There is vague talk of magnets, stator coils and batteries with no details of the actual operation. Output power is used to charge a battery bank. With a 1 KW output, this represents 83 Amps at 12 Volts, or 42 Amps at 24 Volts. They predict fifty years of continuous, trouble-free operation from every motor - the Victorians would be proud of them if they achieved that.

**The Romag and Mini-Romag Generators.** These generators have been displayed on the internet for some considerable time now. They can be found on the Jean-Louis Naudin website: <http://jnaudin.free.fr/html/mromag.htm> which is an excellent website with much specific information, and well worth a visit.

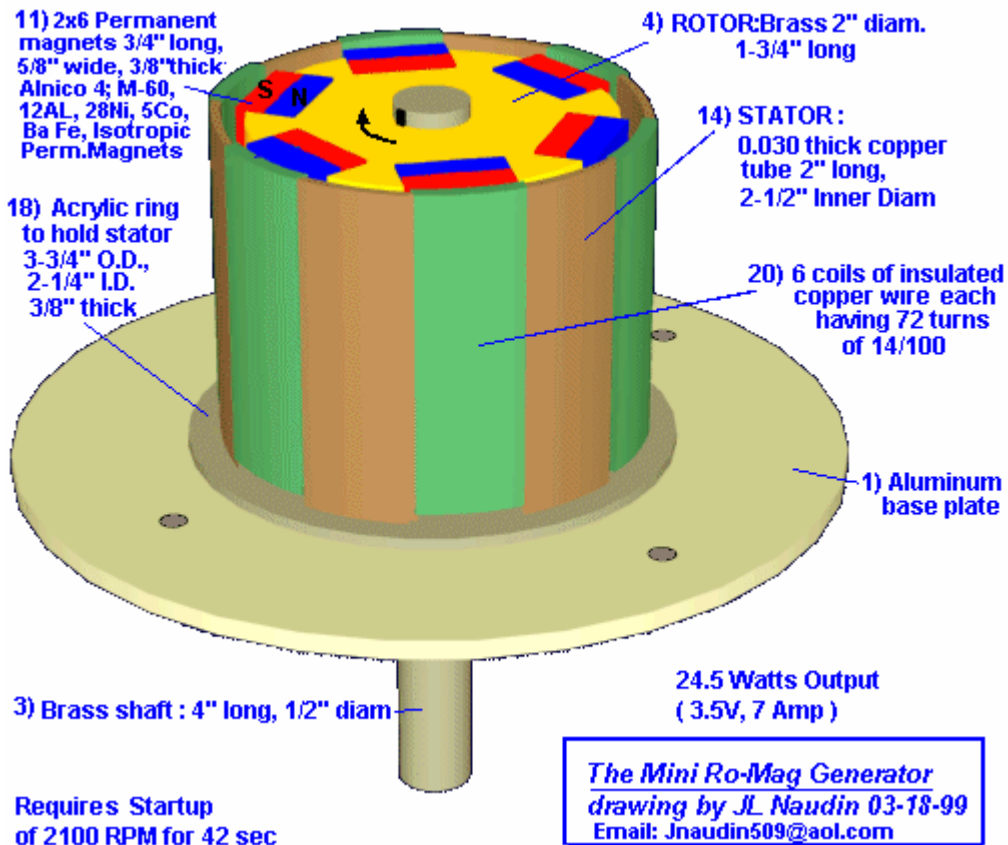

The Mini Romag generator from Magnetic Energy uses the principle of moving magnetic flow named "the magnetic current" for generating electrical power. According to Magnetic Energy this generator is able to produce 3.5 volts, 7A DC (24 Watts) of free electricity plus sufficient power to sustain itself.

This generator needs to be started by using an external motor to rotate it at 2,100 rpm for some 42 seconds. After this, the energy flow is established in the Romag generator and the external motor can be removed and the free electrical energy output can be used.

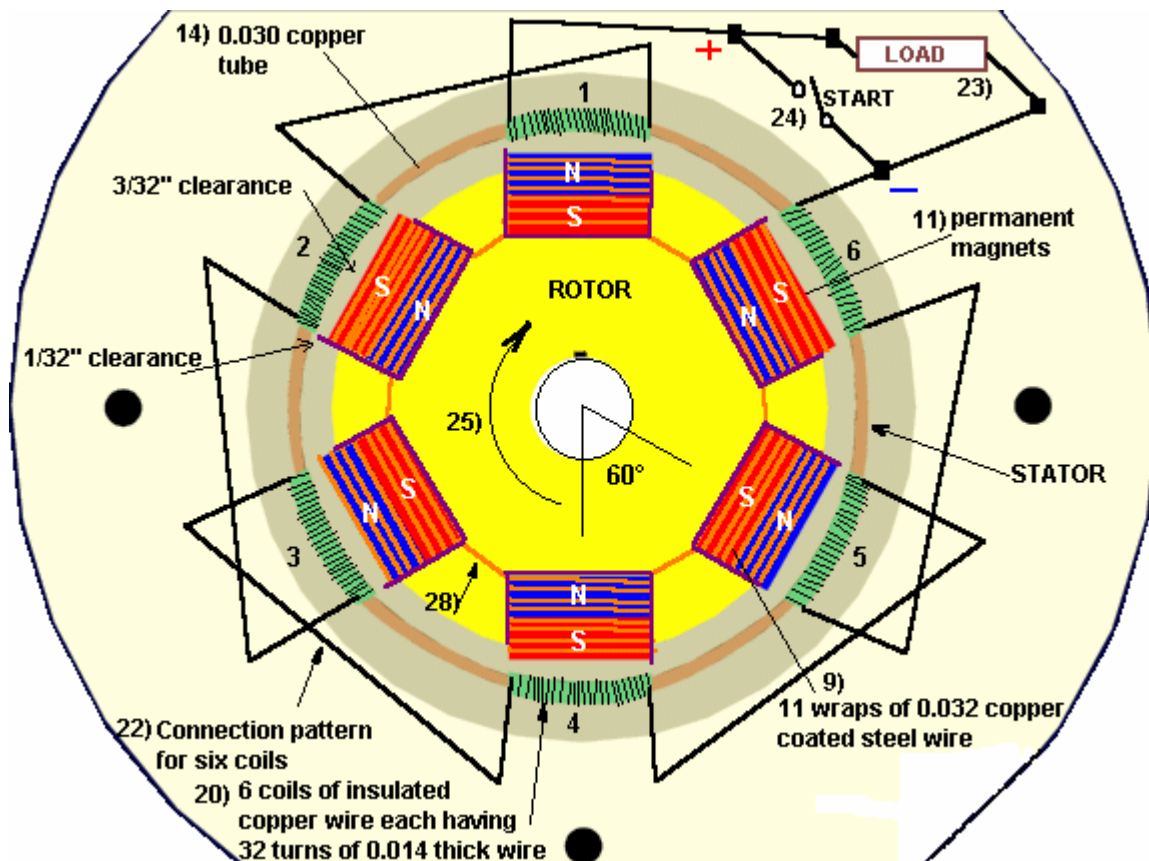

The starting procedure generates magnetic energy within the six coils of copper wire, the copper tube supporting these coils and the copper coated steel wires wrapped around the magnets. This charging is accomplished while the six coil connection wires, (shown as 22 in the above drawing), are making contact and setting up their alternating magnetic poles. After the 42 second start-up time one of these coil connection wires is opened by switch (24 above) leaving the working load in its place. The load (23 above) can draw 7 amps. As current is drawn from the six coils, it sets up magnetic poles which react with the rotor magnets maintaining the rotation. The main shaft is rotated by the 12 permanent magnets as they attract and build a release field. Then the driver unit (hand crank or motor) is disconnected allowing the unit to continue rotating with the load being the **activating** driving force.

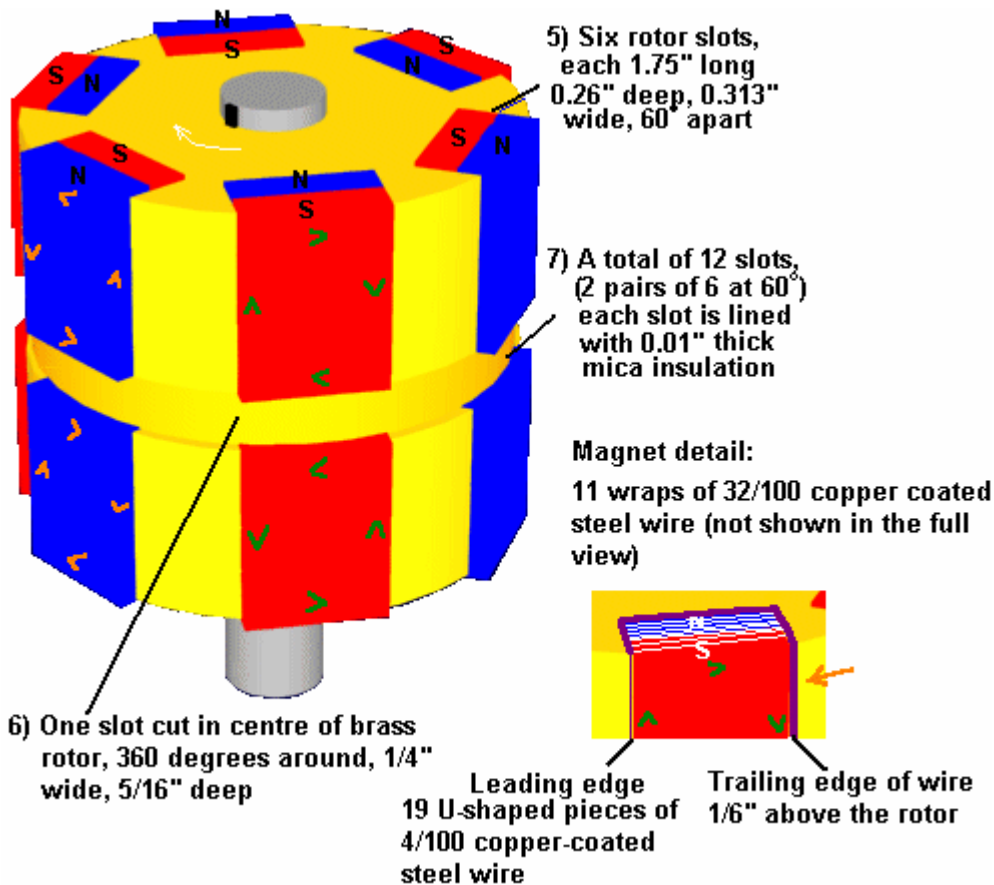

### **Construction:**

If you decide to attempt to build one of these units we suggest using the stated materials:

1. Aluminum Base Plate
2. Sleeve Bearing of oil impregnated brass, 1" long, 0.5" inside diameter.
3. Brass Shaft, 4" long, 0.5" outside diameter
- 4) Rotor, brass 1.75" long, 2" diameter,
- 5) Six rotor slots, each 1.75" long, 0.26" deep, 0.72" wide. These slots are spaced exactly 60 degrees apart.
- 6) One slot cut in center of Brass Rotor, 360 degrees around, 0.25" wide by 0.313" deep.
- 7) 12 slots (produced from the six slots when the 360 degree cut is made). Each slot is lined with mica insulation, 0.01" thick.
- 8) A total of 228 pieces of U-shaped copper coated steel wires, 0.04" thick. Each slot (7 above) has 19 pieces of these wires fitted into the Mica, thus these wires do not contact the Brass rotor. The leading edge of these wires is flush with the Rotor's outer surface and the trailing edge protrudes 1/8" above the Rotor's outer diameter.
- 9) Each of the 12 magnets receives eleven complete turns of 0.032" thick copper coated steel wire. These 11 turns or 'wraps' accumulate to 3/8" wide and the same pattern is placed around all 12 magnets. When placed into the bent wires (8 above), they form a snug fit making firm contact.
- 10) Twelve pieces of mylar insulation, 0.005" thick, are inserted into the cores of the wires (9 above).
- 11) The twelve permanent magnets, insulated with the mylar, must not contact wires of 9). These magnets measure 3/4" long, 5/8" wide, 3/8" thick and are made of a special composition and strength. Alnico 4, M-60; 12 AL, 28 Ni, 5 Cobalt Fe, Isotropic permanent magnet material cooled in magnetic field, Cast 9100 TS. 450 Brin, 2.2 Peak energy product. When inserted in the rotor the outer faces of these 12 magnets are not to be machined to a radius. The center of these magnets pass the center of the coils with 3/32" clearance. The edges, where the wires are wrapped, pass 1/32" away from the coils. This 'changing magnet spacing' aids in not only the release cycle but also contributes to rotational movement. (Sharp magnet edges which are facing the coils are to be sanded to a small smooth radius.)
- 12) Make sure that the magnets are placed in the Rotor with the polarity shown in the diagram.
- 13) The 12 magnet wire wraps are divided into two sections; 6 upper and 6 lower. There are no connections between these sections. The magnetic flow direction between the upper 6 wraps and the lower 6 wraps is attained by the 'flow direction'. The wires are wrapped around the magnet starting at the top 'north' half and then after 11 complete turns the wire exits at the lower 'south' half. As this wire then goes to the next magnet it arrives at an attract wire which is its 'north' side. Thus all wires get interconnected from south to

north magnet half or north to south magnet half. The actual connections should be crimped copper clips (**not** solder) with insulation tubing to prevent contact to the Rotor body.

14) A 0.03" thick copper tube (stiff material) 2" long by 2½" inside diameter.

15) Six slots are cut at the top of tube #14. These slots are 5/8" wide by 1/32" deep spaced at 60 degrees apart.

16) Six slots are cut at the bottom of tube #14. These slots are 5/8" wide by 5/16" deep and in line with the upper slots #15.

17) There are six copper tube mounting points.

18) An acrylic ring is used to hold Part #14, measuring 3.75" outer diameter and 2.25" inner diameter, 3/8" thick, bolted directly to Part #1. This ring has a 0.03" wide groove cut 0.25" deep to allow the six copper tube mounting points to be inserted (part 17).

19) Plastic insulation paper, 0.002" thick, is to be placed around the inside and outside of Part #14.

20) There are six coils of insulated copper wire, each coil having 72 turns of .014 thick wire. Each coil is wound with two layers, the bottom layer completely fills the 5/8" wide slot with 45 turns and the top layer spans 5/16" wide with 27 turns. To be sure each coil has the exact wire length of 72 turns, a sample length wire is wrapped then unwound to serve as a template for six lengths. A suggested coil winding method is to fill a small spool with one length then by holding the copper tube at the lower extension, then start at the plus wire in Figure 2 and temporarily secure this wire to the outer surface of the tube. Next, place the pre-measured spool of wire inside the tube, wrapping down and around the outside advancing clockwise until the 5/8" slot is filled with 45 turns. Then, return this wire back across the top of the coil for 15/32" and winding in the same direction again advance clockwise placing the second layer spanned for 5/16" with 27 turns. This method should have the second layer perfectly centered above the first layer. After winding this coil, repeat the process, filling the small spool with another length of pre-measured wire. A very important magnetic response happens as all six coils have their second layers spaced in this way..

22) Item 22 above shows the connection pattern for six coils. When the unit is driven at start-up (hand crank) for 42 seconds at 2100 RPM, all six jumper wires must be together which means the plus wire goes to the minus wire connected by the start switch. After 42 seconds the load is added to the circuit and the start switch is opened. To double check your connections between the coils, note that the finish wire of coil #1 goes to the finish wire of coil #2, which is top layer to top layer. This pattern then has start of coil 2 (bottom layer) going to start of coil 3 (also bottom layer). When the copper tube with the coils is placed around the rotor, the distance from any magnet to any coil must be identical. If it measures different, acrylic holding shapes can be bolted to the aluminum base, protruding upward, and thus push the copper tube in the direction needed to maintain the spacing as stated.

23) Wires to load.

24) Wires to start switch.

25) Rotational direction which is clock—wise when viewing from top down.

26) Acrylic dome for protection against elements.

27) Coating of clear acrylic to solidify rotor. **Do not use standard motor varnish.** Pre-heat the rotor and then dip it into heated liquid acrylic. After removal from dip tank, hand rotate until the acrylic hardens, then balance rotor. For balancing procedure, either add brass weights or remove brass as needed by drilling small holes into rotor on its heavy side.

28) Insulation tubing on all connections.

29) Shaft for start purposes and speed testing (if desired).

The reason that this generator is included in this section is because the construction is quite complex. Also, the plans have been around for several years without my being aware of anyone constructing or operating one of these units.

**Daniel Cook.** In 1871, Daniel Cook obtained US Patent 118,825 for "An Improvement In Induction Coils". It is by no means obvious how the device described could possibly operate, but as I have no direct evidence that it does not or cannot operate, it is shown here. It is a very simple device which could be interesting to test, especially as it does not involve any electronics or complicated construction. The patent can be summarised as follows:

My invention relates to the combination of two or more, simple or compound, helical coils with iron cores or magnets, in such a manner as to produce a constant electric current without the aid of a battery.

**Fig.1** represents the different parts of a compound helical coil and iron core.



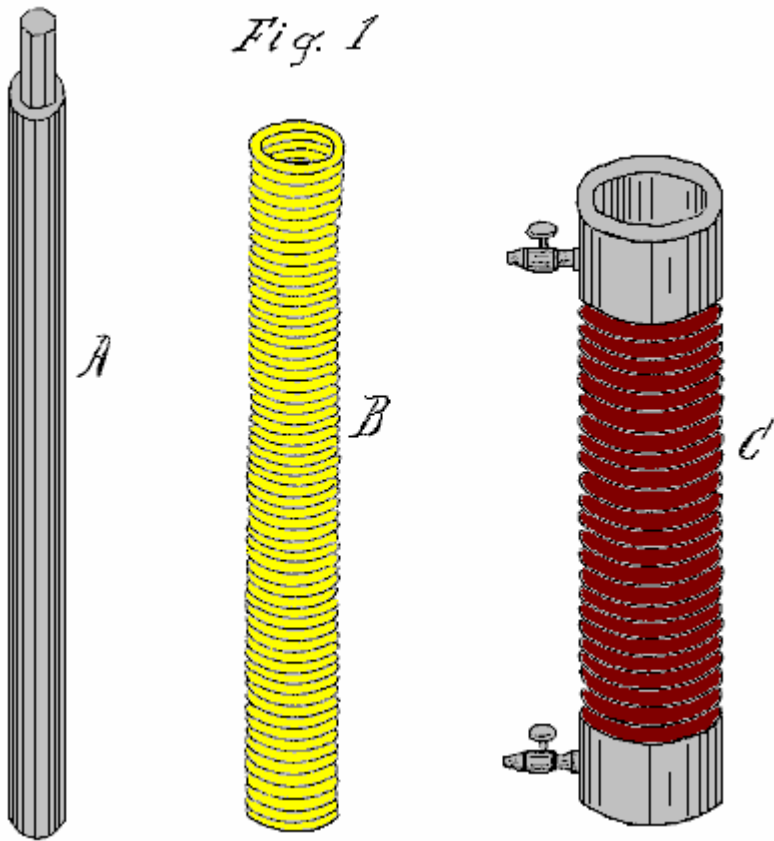

**Fig.2** is a perspective view of my invention.

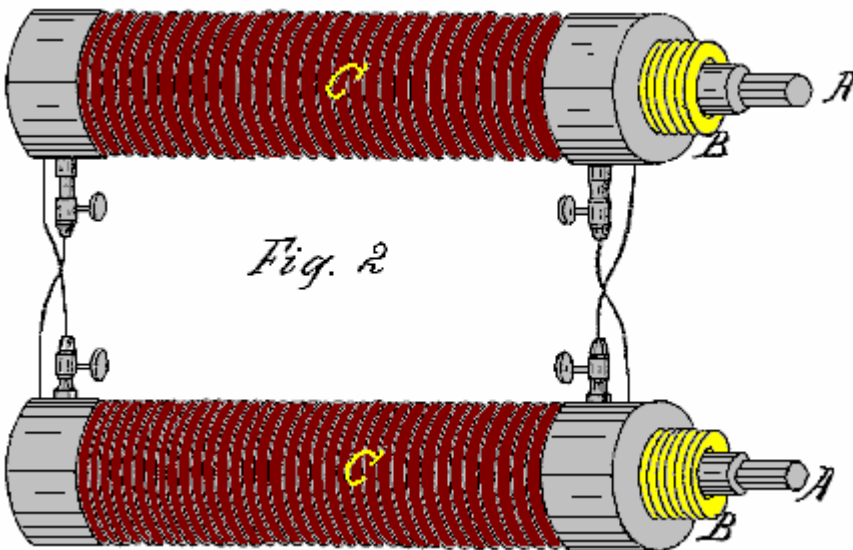

In carrying out my invention, I do not confine myself to any particular mode of coil construction or to any particular size of wire, observing only that the quantity of wire in the various coils must be sufficient to produce the required result; also, the material used to insulate the wires must be suitable for producing the required result. However, I generally prefer to use the same size of wire in the construction of both simple and compound coils.

When constructing simple coils, to produce the required voltage and current, it is desirable to use a long iron core as shown as **A** in **Fig.1**. This iron core may be two, three or even six feet in length, and two, three or more inches in diameter. The coil should be wound from good quality copper wire, insulated with silk or



shellac. The iron core **A** may be a solid bar or a bundle of separate iron wires, the latter giving better results and providing more current for any given wire diameter. While the wire may be fine or coarse, I prefer to use No. 16 or even heavier wire, as the power output is in proportion to the length and diameter of the wire.

When using compound coils, it is preferable in some cases to use a small wire, say, No. 30 or even less, for the primary coil, and No. 16 or even larger for the secondary coil. With this combination, the initial secondary current of the primary coil being very small in comparison to the terminal secondary current of the secondary coil, offers little resistance to the terminal secondary, hence a quicker action is obtained. Alternatively, the primary coil may be of uninsulated wire coiled into a solid helix, being insulated only between the coils, in which case there is little or no opposing initial secondary current.

Helically wound coils alone with large quantities of wire will produce similar results. A ribbon spiral may be substituted for the secondary coil **C**, say, of three, six, twelve or twenty-four inches in width and of any convenient length, but always of sufficient length to raise its output current to the level necessary to sustain itself through its action on the primary coil **B**. In the use of compound coils, it is important that the secondary coil should be wound in the same direction as the primary coil, and the primary and secondary coils be cross-connected as shown in **Fig.2**.

The action will then be as follows:

The secondary current of the secondary coil **C**, will circulate through the opposite primary coil **B**, while at the same instant, a secondary current from the primary coil **B** will be generated and circulate through the opposite secondary coil **C**, both currents flowing in the same direction in the opposite coils **B** and **C**, producing a combined magnetic action on the iron core **A** in the centre. The opposing initial secondary currents of the two coils **B** and **C** being overpowered, do not show in the main circuit **D** of the device, there being eight distinct currents developed in the action of one entire circuit of the two pairs of coils, two terminal and two initial secondary currents to each pair of coils, the four initial secondaries constantly opposing the circulation of the four terminal secondary currents, but the initial secondaries being of much lower voltage and current than those of the terminal secondary, are overcome, leaving a sufficient surplus terminal power to overcome the resistance of the primary wire and charge the bar **A** to the degree needed to reproduce itself in the opposite secondary coil. By this means, a constant current is kept flowing in all of the coils.

These coils may be constructed using 500 feet to 1,000 feet or more for each of the primary and secondary coils. The longer, and better insulated the wire, the greater is the power obtained from the device. The larger the wire diameter, the greater the current obtained.

If only single coils are to be used, it is preferable to have a wire length of 1,000 feet or more in each coil. The action is the same as with the compound coils, but only four currents are produced: two initial and two terminal currents, the latter flowing constantly in the same direction - in effect, there being only one current in the same direction.

The action in the coils may be started by using a permanent magnet, an electromagnet or by pulsing an extra coil wound around the outside of one of the coils of the device. If the load circuit is broken for any reason, the current stops immediately. It is then necessary to perform the start-up procedure again to get the device restarted. This can be overcome by permanently connecting a resistor across the terminal of the load so that if the load circuit is broken, the device can continue under very much reduced current until the load is restored. By this means, the device becomes the direct equivalent of a battery.

A rheostat **D** may be introduced into the main circuit to limit the current and prevent the overheating of the coils through the drawing of excessive amounts of current. The iron cores may also be used for producing electromagnetic motion when the device is operating.

**Cold Fusion.** Cold fusion was initially accepted with great excitement. It then appeared to be discredited. At the present time, there are many people researching this area. In essence, it is said that nuclear fusion can take place at room temperature, under certain conditions. At this time, the developers are struggling to develop a serious working device. They are still at the stage of measuring neutron emissions to assess if the device is working. A practical free-energy device based on this method appears to be some time away yet.

There are several web sites which follow the progress in this field, including “Cold Fusion Times” at <http://world.std.com/~mica/cft.html> where considerable detail is available.

**Moller’s Atomic Hydrogen Generator.** One very different and already successful experiment can be found at <http://jlnlabs.imars.com/mahg/tests/index.htm> where the highly resourceful researcher JL Naudin shows many successful tests on the Irving Langmuir system which can be found at the <http://jlnlabs.imars.com/mahg/article.htm> website. Please check out these very well presented sites. Just to give you an idea of the type of content:

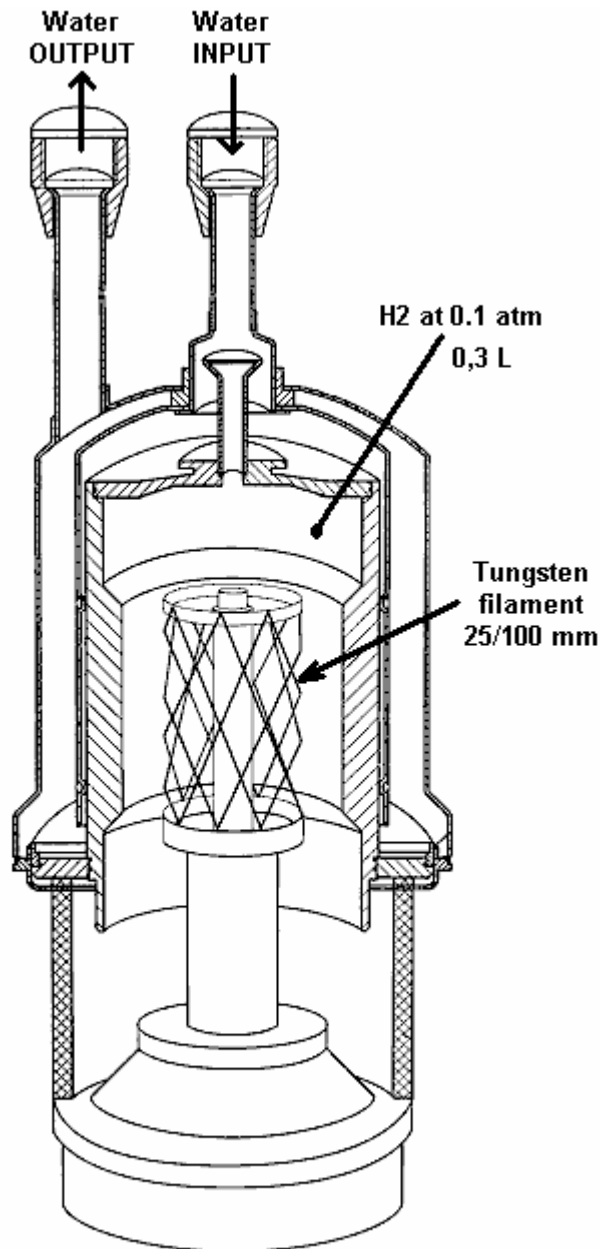

The MAHG (Moller Atomic Hydrogen Generator)

Results of the test:

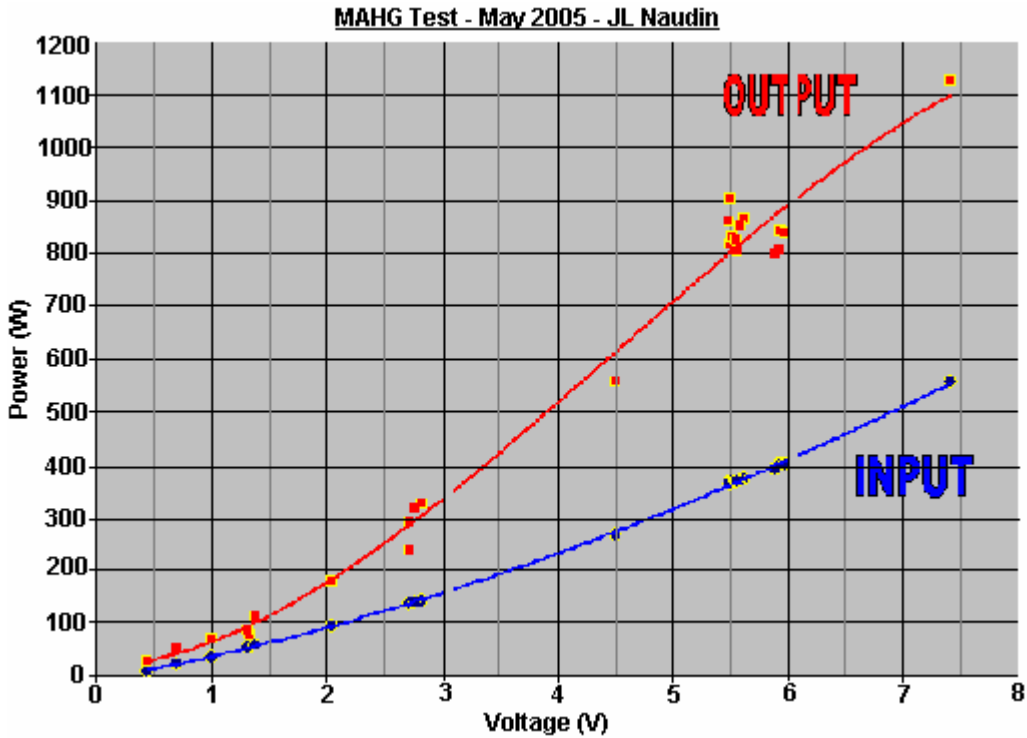

**Muammer Yaldiz's 'OceanStar' Electrical Generator.** This is a purely mechanical device which is self-powered and which can provide electric current to drive other equipment. Designed and built in Turkey, it was demonstrated in Dortmund on 17th October 2005. details can be seen on the <http://www.ocean-star.org/center.html> web site, including video footage of the demonstration with commentary in both English and German. The demonstration was conducted by J. L. Duarte who ran an independent test and produced a report dated 17th July 2005 on behalf of the Department of Electrical Engineering, Electromechanics and Power Electronics of the Eindhoven Technische Universiteit. Muammer has obtained Patent Application WO2004091083 for his design. The demonstration was of his portable unit which outputs some 12 volts DC:



During the demonstration was used to light a car lightbulb very brightly:



Muammer has also produced a larger version capable of powering a house:



The demonstration unit was started using a 16 AHr battery for a few seconds. Once the unit reaches its running speed, it becomes self-powered and capable of delivering substantial electrical power and the starting battery is then disconnected. In theory, no mechanical system can produce 100% efficiency, let alone more than 100%. However, it appears that automotive and marine alternators may well operate well in excess of 100% efficiency and so it would not be impossible for Muammer's device to actually work.

The report by Dr. J. L. Duarte on the smaller unit provides the following information:

This technical note aims at describing a test which I personally conducted in Izmir, Turkey on 17th July 2005. The purpose of the experiment was to check the energy balance with respect to input and output of an apparatus which was the embodiment of the invention described in the international patent WO 2004/091083 A1 (shown below).

The apparatus was confined inside a metallic box sized 550 x 380 x 270 mm, weighing some 20 Kg, and I was allowed to inspect everything outside this box. However, in order to protect the core ideas of the invention, I was not supposed to check all the details of the internal parts. According to the inventor, the apparatus is predominantly a mechanical system, without any kind of energy storage inside the box (such as batteries, accumulators, flywheels, combustion motors, chemical or radioactive reactions). I believe the intentions of the inventor to be in good faith.

The experimental set-up was quite simple, as shown schematically in **Fig.1**. It consisted of placing the box with unknown contents, from which DC voltages and currents were expected to be generated, on a table in

the middle of the room. A cable with two terminal contacts was run from the box and instruments were placed between the box and the load, which was a standard DC/AC inverter driving an incandescent lamp. The output power from the box was measured before the load connection as shown here:

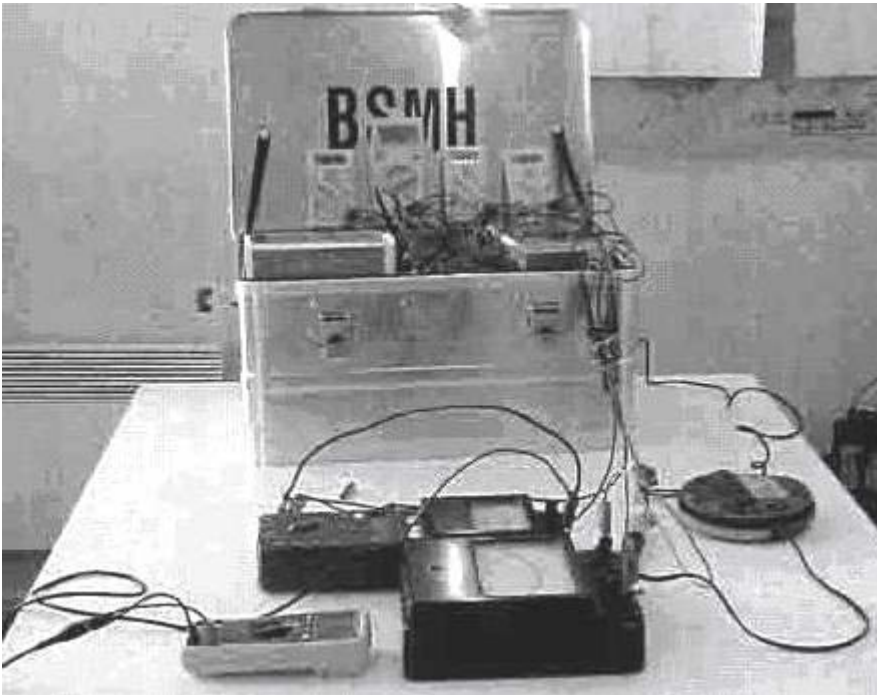

The circuit connection method used is shown here:

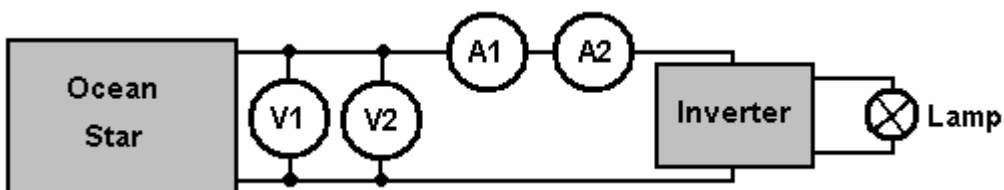

After a short start procedure, the metallic box and the load were both fully isolated from the environment, ensuring that there was no physical contact or connection to external power sources such as the public electric mains supply, at any time during the whole duration of the measurements. As the start-up energy input to the apparatus was quite modest, the main issue was then to measure the delivered energy output.

I had prepared the power measurements with care, by using reliable instruments which I personally brought with me from my own University laboratory. In order to measure the DC voltage directly out of the positive and negative terminals, I used two different voltmeters connected in parallel. One voltmeter was an analogue type, constructed with permanent magnets and wires, while the other was a digital voltmeter. To measure the DC current I used two ammeters in series, one analogue and one digital. If electromagnetic waves should interfere with the measurements, then they would disturb one or other instrument, but not all four pieces at the same time and in the same way.

Before starting the test, no audible sound was being produced by the apparatus. The measured voltage and current at the terminals were zero. So, as far as I could observe, the apparatus was completely at rest.

The start-up procedure consisted of connecting a small 12V DC lead-acid battery to two contact points inside the box for a few seconds. I checked the time using my own watch and it was more than 5 seconds but less than 10 seconds. I consider it reasonable to consider the time to have been 8 seconds. After that time, no energy input was connected to the box by means of cables.

Immediately after the start-up procedure, I could hear noise such as would be produced by parts rotating inside the box. The inventor said that some ten minutes should be allowed to elapse before the load was connected. During that time, both of the voltmeters showed the output voltage dropping slowly from 12.9 volts to 12.5 volts. The two voltmeters matched accurately. In the following hours, I observed and recorded

by hand, the voltage and current values displayed by the instruments. The displayed values were quite stable, so I initially decided to note them at 15 minute intervals, but later on at 30 minute intervals.

From time to time, using my hands, I attempted to find a temperature gradient inside the box, but I could not detect any variation or increase in the temperature compared to the room temperature. After five hours, I took the decision to stop the measurements. The results are shown in the following table:

Time	V1 (Digital)	V2 (Analogue)	A1 (Digital)	A2 (Analogue)
0:00	12:54	12.5	2.23	2.35
0:15	12.57	12.5	2.29	2.35
0:30	12.57	12.5	2.29	2.35
0:45	12.53	12.5	2.27	2.35
1:00	12.51	12.5	2.27	2.35
1:15	12.48	12.5	2.27	2.35
1:30	12.47	12.5	2.27	2.35
2:00	12.41	12.4	2.26	2.35
2:30	12.35	12.4	2.26	2.35
3:00	12.30	12.3	2.25	2.35
3:30	12.22	12.3	2.25	2.3
4:00	12.15	12.2	2.25	2.3
4:30	12.01	12.1	2.24	2.3
5:00	12.00	12.0	2.23	2.3

\*\*\*\*\*

As far as I am concerned, the above table of results kills the proposed system stone dead. The voltage readings are absolutely typical of an inverter powered by a lead-acid battery. I have tested many batteries in exactly the same way and the table looks 100% familiar. If the box contained a genuine self-powered generator, then I would expect the output voltage to remain constant under the constant current drain. In my opinion, it was wholly irresponsible to have stopped the test after just five hours with the output voltage falling steadily. If the output voltage had been rock steady at 12.5 volts for the whole five hours, then that would not have been quite so bad but with it going down 12.3, 12.2, 12.1, 12.0 in the last four 30-minute intervals, and with a lead-acid battery voltage of 11.5 for a fully discharged battery, it was wholly unrealistic to stop the test. A further ten hours of testing should have been undertaken.

For that reason, the OceanStar information is placed here, among the "Unlikely to Result in a Workable Device" section. However, on the basis that I am not infallible and it is possible that this system may actually work as described, here is the information from the Patent Application WO2004091083 although the quality of reproduction and the clarity of the wording is not particularly good:

**A SYSTEM WHICH GENERATES ELECTRICAL POWER VIA AN ACCUMULATOR THAT PROVIDES THE INITIAL MOTION FOR THE SYSTEM**

**ABSTRACT**

This is a portable system that generates electrical power via an accumulator that provides the initial motion for the system. Two batteries are used in this system and the system is kept working via the initial motion provided by these batteries. There is no need for another transformer. This device works using its own mechanism and there is no need for additional devices. In this way, a continuous electrical power generation is possible. This device can work without connecting it to a network so it is possible to use it at places where electricity does not exist. Moreover, when connected to the entry of a building, the need for a network is avoided. This system generates electrical power independent of a network.

## **DESCRIPTION**

A system which generates electrical power via an accumulator that provides the initial motion for the system. This is a portable system that generates electrical power via an accumulator that provides the initial motion for the system. Already existing systems can generate electric power of whose duration depends on the lifetime of the battery. In these systems, the battery has to be reloaded in order to restart the system. 12V electrical power provided by the batteries used in cars is increased to 220 V via transformers.

Two accumulators are used in our invention. The system works on a continuous basis after the initial start up via these accumulators. There is no need for another transformer. Our system, which generates electrical power, does not need any other devices and it keeps on generating energy via its own mechanism. Also, the system works without connecting it to a network.

Thus, it can be used at any place where no electricity exists. Nevertheless, when this system is connected to the entry of the buildings, there is no need for an additional network. The system can produce electrical power independent of a network.

## **DESCRIPTION OF THE DRAWINGS**

Below are the explanations of the figures that provide a better understanding about this invention.



Fig.1 is a schematic view of the system.

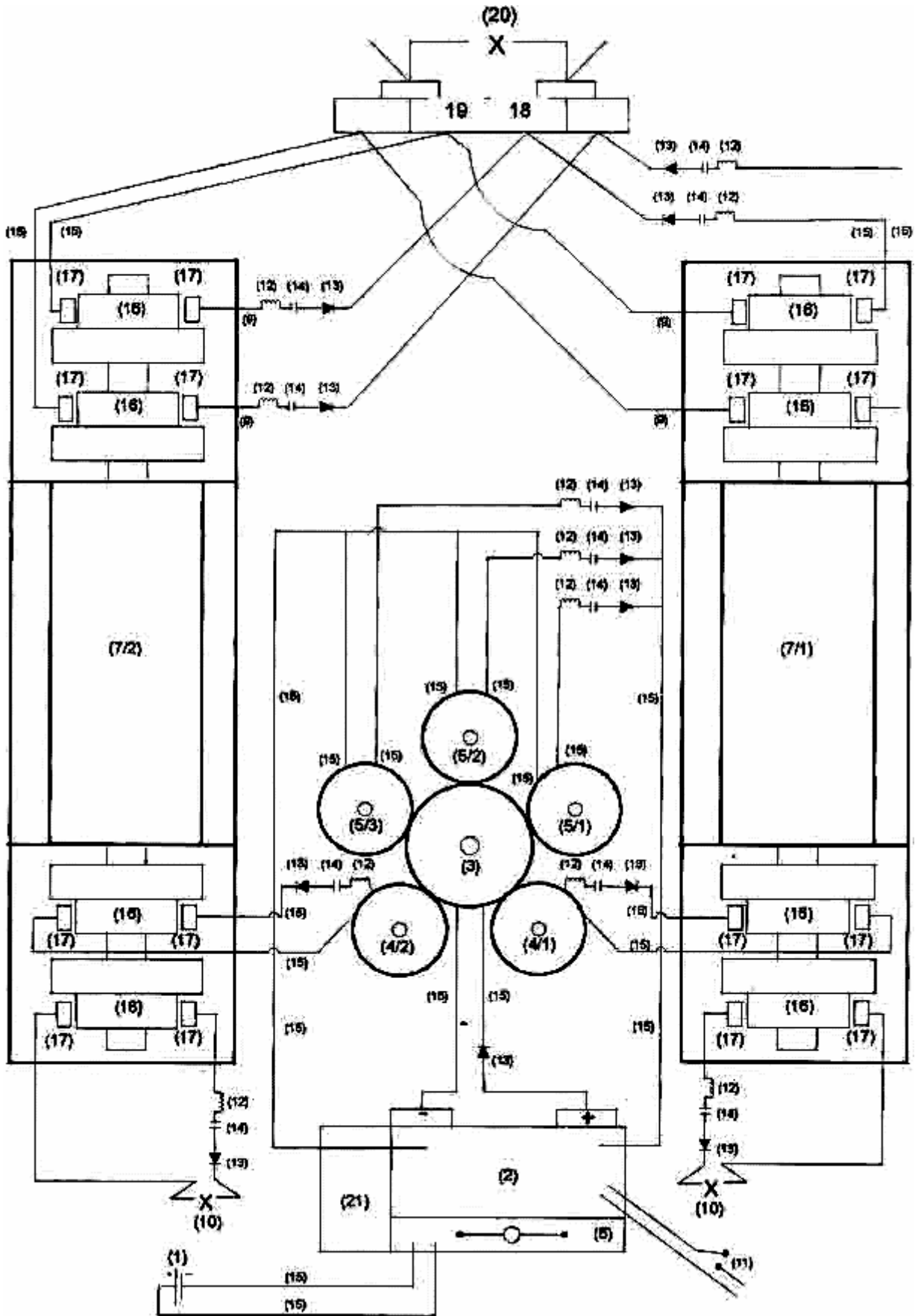

Numbers used on the schematic:

1- Accumulator

- 2- Regulator
- 3- Big Gear 3/1-Starter dynamo
- 4- Small gear 4/1-2-Feedback dynamo
- 5- Small gear 5/1-2-3-Feedback dynamo
- 6- Contactor
- 7/1 and 7/2- Commitatris
- 8- 29 DC input
- 9- 24 DC output
- 10- 580 DC output 11-Switch
- 12- Shunt
- 13- Rectifier
- 14- Capacitor
- 15- 2.5 mm cable
- 16- Collector
- 17- Charcoal
- 18- Fixing clamps
- 19- Fixing clamps
- 20- Lamp
- 21- Conjector
- 22- Starter dynamo
- 23- Feedback dynamo
- 24- Alternating current dynamo
- 25- Magnetic switch
- 26- Pulley
- 27- Pulley
- 28- V pulley
- 29- 380V current output
- 30- 220 V current input

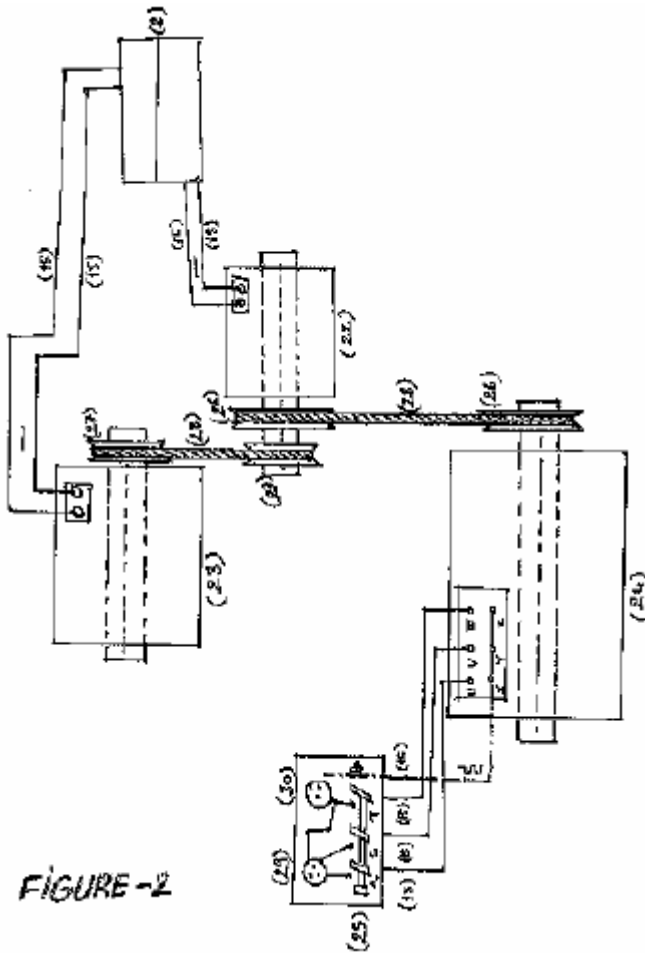

FIGURE -2

**DESCRIPTION**

This invention is a system that starts working via the motion of alternator. There exist two accumulators(1), and the first motion provided by the accumulator is carried to the regulator. Contactor (6) keeps the starter dynamo working by disconnecting the accumulator (1) once the regulator (2) is put in. The voltage coming from the accumulator (1) passes through the regulator and the start dynamo (3/1) starts working and thus the feedback alternators via the gears (4/1-2-5/1-23-3). Feedback dynamo start sending pure DC current to regulator via shunt (12), capacitor (14) and diode (13). It connects all the currents that reaches to the regulator in 4 seconds and sends to the contactor (6). Accumulator (1) is put out by this current that reaches to the regulator. This current is transformed to the started dynamo (3/1). There becomes a transformation within the system. In case of electricity shortage, it keeps on working by using the current generated by the commutatoris (7/1).

Via the starter dynamo(3/1), DC is generated in the alternators which are connected to the gears and this current is transformed to the commutatoris (7/1 and 7/2) and DC voltage is generated at commutatoris (7/1 and 7/2).

Second System: 3x24 DC voltage is transformed to the second starter dynamo (22). Once the start dynamo works (22), a feedback dynamo (23) having a pulley system and a feedback dynamo (24) generating alternating current starts working. The feedback dynamo (23) starts feeding back; the feedback dynamo (24) which generates alternating current is independently generating 6 KV, 18 Amp, 50Hz current. Moreover, first system produces 24 DC and 580 DC current on its own.

The bigger the gears are, the more the generated current is.

This system, which is the subject of our invention, can be used at any place. You can use it at places where there exist no electricity, or at places such as villages, cities, buildings, greenhouses where there is no network. Moreover, network is no longer a must. Instead of a network, you can use our system. There is no need for gasoline when this system is used in vehicles.

## **CLAIMS**

1- This is a system where the initial motion is provided by an accumulator and the following items constitute the system: two accumulators (1) that provided the initial motion for the system, a regulator (2) and a starter dynamo (3/1), three feedback dynamos (5/1-2-3) connected to the gears of the starter dynamo, two alternator dynamos (4/1-2) which are connected to the gears of the starter dynamo and also two commutatoris (2/1-2) working via the generated energy and also a feedback dynamo (23) and alternating current dynamo (24), as the second system, that works via the voltage generated by the first system.

2- It is the system mentioned in the first claim and it is related to the feature that the first motion is provided from the accumulators to the regulator (2) and the start dynamo (3) and the commutatoris (7/1-2) start working feedback dynamo (23) and alternators (4/1-2) and the voltage enters the regulator and puts out the accumulator (1) via contactor (6).

3- It is the system mentioned in the first claim and it is related to the feature that the accumulator can be reloaded by the help of connector when needed.

4- It is the system mentioned in the first claim and it is related to the feature that it can be used either as direct current or as alternating current.

5- It is the system mentioned in the first claim and it is related to the feature that the regulator regulates both the voltage of the first system and the second system and provides two main networks that provide the needed electricity

\*\*\*\*\*

### **The Current Situation:**

If we believe what we are being told (and there seems to be very little reason not to), many devices have been developed which have a power output greater than the power we need to supply them to make them operate. There must be hundreds if not thousands of these devices. The big question is: why are none of them available off-the-shelf and ready to buy? To answer that question, let me quote Joe Mackem of the USA:

## ***Suppression of Free-Energy Devices and Inventors***

**By Joe Mackem**

There has been a revived energy revolution movement going on around the world the past twenty years which has not been covered or reported by the mainstream press, establishment, scientific journals or university research publications.

Most of the discoveries have been made by people with curious, ingenious minds, who on many occasions have observed experimental results in cold fusion, superconductivity and magnetic motors, that appear to violate the currently held laws of physics, chemistry and electrodynamics. A term has been used to describe such phenomena, is called 'over-unity energy' or 'free-energy', which in many cases means getting more energy out of a system or reaction (magnetic motor or cold fusion reaction) than appears to be put into it. A better explanation is that excess energy is being accessed from as yet not completely explained source. (Note: An atom bomb is an over-unity device which gets a tremendous amount of extra energy out, in the form of harmful radiation, which is needed to trigger the reaction.)

The first question that usually pops into a sceptic's mind is that if the technology is for real and discoveries have been made, such as Pons & Fleischman's cold fusion cell or Rory Johnson's fusion magnetic motor, why has it not been reported or mass-produced for use by our energy-hungry world? The answer is suppression. What is meant by 'suppression'? Suppression can be an active type --where a corporation or oil company or OPEC, who does not want the invention marketed, will blow up or destroy the laboratory and the prototypes and threaten to kill the inventor if he again attempts to market the revolutionary device. The other type of suppression is the passive type where a competing company, who has big bucks, such as some of the major oil companies, will come in and buy out a patent with no intention of bringing it to market until the demand for oil greatly exceeds the supply and gas prices soar, then they will start marketing a 100 mpg carburettor for ICE (Internal Combustion Engines).

Other types of passive suppression include universities which are receiving big funding from oil or nuclear establishment sources, refusing to do research, or muzzling bright professors (by withholding tenure) from publishing theories and results as to the what, how's, and whys of these over-unity motors and cold fusion reactions. Or the example where a Patent Office refuses to grant patents in revolutionary technology, claiming perpetual motion machines, as they see them, aren't patentable, or if they are patentable, that they can place a Secrecy Order on the patent, which prohibits the inventor from disclosing any information to anyone "since such disclosure might be detrimental to National Security".

To the best of our knowledge, the following accounts of suppression are true. This information will hopefully show you some of the reasons why this over-unity technology has not reached world-wide attention or use. Perhaps perpetrators of this much-needed new energy technology suppression will consider reversing their policy and incorporate this technology into their business structure for a future profitable enterprise.

The development of free-energy technology has really captured the imagination of ingenious, non-conformist inventors. Pioneers whom they have admired include Nikola Tesla, John Keely and T. Henry Moray. Two primary areas of R&D have been targeted:

- 1) Clean cold fusion (as opposed to dirty hot fusion - nuclear energy), and
- 2) Zero-point energy.

Again, these technologies have been actively and passively suppressed. The following documented accounts, will hopefully, give you some specific instances of suppression.

In the late 70's a brilliant inventor, Rory Johnson of Elgin Illinois, invented a cold fusion, laser activated, magnetic motor that produced 525 HP, weighed 475 lbs, and could propel a large truck or bus 100,000

miles on about 2 lbs of deuterium and gallium. This was years before Pons & Fleischman or Dr. James Patterson entered the scene with their cold fusion technology. Rory Johnson was in the process of negotiation with the Greyhound Bus Company to install this revolutionary motor in a few buses to demonstrate the fuel savings, reduced maintenance and more profitable balance sheet for Greyhound.

The mistake Rory Johnson made (little did he know that OPEC was keeping close track of any future competition to their oil business and that he was number one on the hit list) was to actively publicise his advanced fusion-magnetic motor in many magazines, telling of his plans to manufacture and distribute this revolutionary motor nation-wide. (I have even talked to a few people who had signed up for a distributorship). Coincidentally, after agents of Greyhound tried to get in touch with Rory Johnson after a year of no contact, they were notified that Rory had passed away unexpectedly. A man of robust health in his early fifties dying?! It was later learned that for some threatening reason, Rory moved out of his laboratory unexpectedly in the middle of the night with all his motors and technology and moved to California before he died.

Another astounding development that surfaced was a Restraining Order, or gag order, by the U.S. Energy Department which was placed on Rory's Company, Magnatron, Inc., prohibiting him from producing the Magnatron engine. Appendix 1 contains a letter from Minnesota State Senator Marion Manning to U.S. Senator from Minnesota, Dave Donenberger inquiring as to why our government would place such a gag order on Mr. Johnson. Isn't this the land of the free market economy? Apparently not. Something seems a little strange about this whole incident. Are the oil cartels dictating energy policy to the U.S. Government?

Remember Ruby Ridge, where over zealous U.S. agents killed Randy Weaver's wife and son? Well at the same time of this FBI siege, another inventor happened to be living in Northern Idaho and working on an advanced zero-point energy device. As the story goes, (told first hand to me by the investor), an investor was coming to visit the inventor who had just made a breakthrough in his free- energy device, but who had made the mistake of publicising his breakthrough on a local TV station. The day before the investor arrived, two government agents broke into the inventor's home, surmising that both the inventor and his wife were away. It just happened the wife was still at home and was very familiar with the use of a hefty handgun. At point blank range, she held the agents at bay inside her house while she debunked their excuse that they were cable TV repairmen checking out their cables lines. If it wasn't for the siege of Randy Weaver at Ruby Ridge, who knows what else would have happened that day.

By the way, whose side is our government on? It appears that the big money interests, oil cartels, and nuclear power companies have control of it. These big powerful corporations don't want any competition. They spend most of their research funds on technology which is not necessarily new or revolutionary. It appears it isn't what's in the interest of National Security or Balance of Power in the Middle East, but what is in the best economic interest of the multinational corporations. A classic example is the government-funded hot fusion reactor at Princeton's Plasma Physics Lab. The "powers that be" know there are cleaner, safer and cheaper ways of producing nuclear energy, like bombarding lithium with protons -- known since 1932, but has been kept secret and kept out of college textbooks. Read "The Fifty Year Nuclear War" by David Sereda in the Jan/Feb 1996 issue of "Perceptions" for more eye-opening details. This is a classic example of passive suppression of new, clean, economical alternate cold fusion energy.

Now for some real active suppression! About 10 years ago, some very clever backyard inventors took a magnetic generating flywheel off a Model-T Ford, placed stationary magnets in a spiral arrangement outside it, and produced a self-powered motor-generator. The motor-generator (using the pulsed varying distance magnetic spiral principle), continually produced 1600 watts of power with no outside power input. They demonstrated the generator at UCLA, which confounded the professors, students, and other onlookers. Evidently there were some heavy-handed corporate types in the audience, because the inventors never made it home from the demonstration. The two demonstrator-inventors were found dead along the highway, and the trailer with the generator inside was missing.

Now the Japanese apparently have the technology which is referred to as the "Magnetic Wankel Motor". Yasunori Takahashi, a famous Japanese inventor who developed the beta video tap, has retrofitted his newly developed super powerful Yt magnets into a 15 HP Magnetic Wankel motor scooter and claims he can get 15 HP from a few amperes of electricity input. Now when the Japanese start to import these scooters into the U.S. (if our U.S. Government will allow it), there goes our further balance of payments deficit to Japan. Incidentally, rumour has it that Mazda tried to import the Magnetic Wankel engine in a Mazda several years ago but was refused entry by the U.S. Government, as was a super-high-mileage, gas-powered Honda which was kept from entry into the U.S. a few years ago by our government. Let's hope U.S.

Government policy changes, before it becomes more bankrupt due to the increasing balance of payments deficits with Japanese manufacturers and foreign oil companies due to the wasteful, gas-guzzling technologies we have come to embrace as The American Way.

Now for another account of suppression which includes a 'black helicopter' incident:

Someone presented a video tape of an advanced tachyon generator which accessed tachyon waves. It not only produced excess energy, but it also exhibited time-warping characteristics. This presentation was made at an annual Tesla conference in 1993, without the inventor's permission. The video tape was shown on a Friday afternoon, at a location 3,000 miles away from the inventor's home. The very next day, U.S. Government agents were knocking at the inventor's door wanting to see the device. He told them 'no thanks', and the following day, a black helicopter was hovering overhead taking pictures of the inside of his house. The black helicopters and possibly even satellites apparently now have the capability of photographing every item inside a building.

A similar situation occurred with another inventor. He was experimenting with an advanced form of plasma-discharge energy. The very next day, while he was at work there was a black helicopter hovering over his house for several hours, evidently taking pictures of this technology in his basement.

Another story: In 1995, a man named Volcheck of Grand Coulee, Washington, made a trip across the United States and back, in a car powered by a special gas which he developed and which had unusual expansion properties. He claimed to have obtained the formula from some unpublished notes of Leonardo Da Vinci.

He says the gas expands enormously at about 395 degrees Fahrenheit to 450 pounds pressure. In other words, from approximately 390 to 395 degrees Fahrenheit, the gas expands from a volume of one unit to a volume of 10,000 units. He used this gas in a modified Franklin aircraft engine which behaved more like a steam engine. He never refuelled during the trip, consuming \$10 worth of this special gas. Soon after his return, some congressmen invited him back to Washington, D.C. for a special hearing and congratulatory meeting. While he was gone, Federal Marshals or a S.W.A.T. team forced entry into his shop, confiscated or destroyed his record-setting car, plans, components, special gas containers. They subsequently told him to forget any more projects like this.

An inventor and a Ph.D. Electrical Engineer from one of our prestigious universities had made a breakthrough on an over-unity motor and hired a hall in a mid-sized town in the U.S. to show off their new discovery. It was an impressive demonstration. What happened next was also (suppressive) impressive. A black van, with windows that you couldn't see into, staked out their lab. Three weeks later, a S.W.A.T. team of six kicked down the lab door, and with axes, destroyed half a million dollar's worth of equipment in one-half hour. They forced the inventors onto the concrete floor, face down, and held their heads against the concrete, until bleeding occurred and the equipment was destroyed. They said they were looking for the nuclear source. They had no warrants, just "S.W.A.T. TEAM" printed on the backs of their brownish uniforms. The inventors were told to cease all further development, and the apartments one of the inventors owned were condemned. The tenants were ordered to leave and the Ph.D. Electrical Engineer is still being harassed by the IRS.

The late Floyd Sweet developed the 'Vacuum Triode Amplifier', an advanced solid-state, magnetic over-unity device. In the late 1980s, a man claiming to represent a conglomerate, met up with Sweet and told him he did not want the VTA to come onto the market at that time and said, "It is not beyond possibilities to take you out of the way".

One Free-Energy researcher says:

The Powers that be made me angry! I do not like my telephone tapped, tracers put on my automobiles, round-the-clock surveillance, and my mail messed with. I do not like the 'little' things that 'happen' around me. The only reprieve I got last summer was when the agents watching me were pulled off to join the siege of Randy Weaver. Can you imagine 400 men surrounding a man's cabin, killing his wife and only son, just because he wanted to be left alone? It's a long story, but that's what it amounts to.

The United States Patent Office has a policy which prohibits the patenting of a 'perpetual-motion machine'. This policy is a case in point, of what happens when you have too much government intervention. Why

make a policy against something that you believe is impossible? A second irony to the situation, is that the Patent Office already allows patents on devices which don't work! So why would they care if a perpetual-motion or an over-unity machine works or not? Their real function is simply to record the patent when the inventor applies for it. If it works or not, really isn't their job to say. They exist to have records on file so that the inventor can point to a specific place and time and say, "See, I invented it before you?" and therefore have the manufacturing and sales rights for a given amount of time! That's all! That's it!

In my opinion, the U.S. Patent Office way oversteps their function by discriminating against many patent applications. But then, their attitude has been strange for a long time. Charles H. Duell, director of the U.S. Patent Office in 1889 states, '...everything that *can* be invented... *has* been invented.' I always chuckle when I think of that.

In reality, in our so called 'Free-Enterprise' system, the marketplace will determine the value of a patent. A patent for something that doesn't work or is impractical when applied as a device simply won't sell. A device that is superior has a chance to take over from the existing technologies. How many people really care what happens when they flick on the light switch? Most people simply want the light to come on! And if they can get the same light for a fraction of the cost, then they would care about the saving without worrying about the 'new' technology which made it possible. Practical devices will sell, and it shouldn't be up to the Patent Office to determine the practicality of a device.

You can believe it or not, but we live in a police state. The United States and Canada have only the illusion of 'freedom'. I'd very much like you (or anyone) to prove this statement wrong for two reasons. First, I really want to be free and have the rights granted me by the original Constitution. Second, if you look into the subject hard enough to prove me wrong, you'll find that I'm right and you'll be educated, which is my intention. I still retain the hope that, if enough people get together, we can turn our countries back into the dream held by our ancestors.

Incidentally, suppression occurs in other countries as well. Johan Grander of Austria developed a revolutionary magnetic motor, but was turned down by the Austrian Patent Office with the excuse: "Inventions which are detrimental to products in existence may not be granted a patent." There are at least 20 cold-fusion patents on hold here in the U.S. - another form of passive suppression.

### **Some Reasons for Over-Unity Suppression:**

The strong oil lobby has throughout recent history suppressed high-mileage carburettors through violent threats or rigid mandates. Their tremendous investments in oil fields, refineries and distribution systems wields a big stick against free-energy, over-unity systems. (They have to be informed, that it will take tens of years to implement this technology).

Some have said the world is on the "brink of financial collapse and any revolutionary breakthrough in the energy production or distribution system could cause upheavals in our economic system which is based on finite sources of money and energy".

The powers that be can control the masses by controlling the energy supply. They don't want to lose that control. As Einstein stated, "Great ideas often receive violent opposition from mediocre minds." The egos of competing companies, or establishment views that this technology is a hoax, can also create these violent oppositions.

The unenviable tasks of adding to, or changing, some of the laws of classical physics and chemistry will take vast amounts of research time before verification of these new discoveries can be made by the ivory-tower university types.

People in power (academic, political, technological, or business) do not like revolutionary changes which might threaten their position or standing.

National Security: This technology used in a war would be a decided advantage.

To summarise: I am writing this for three main reasons.

1. To inform the public that this new energy revolution is for real, or why would the competing establishment corporations OPEC, etc., and government agencies be carrying on such suppressive endeavours? Write



to your legislators and inform them as to what is going on. Tell them we need this new revolutionary technology to be developed world-wide, including the US. It is an almost foregone conclusion, that the extreme weather events we are experiencing are a result of mankind's careless exploitation of the earth's resources.

2. To inform the inventors not to make sensational claims on their local TV stations or newspapers about recent breakthrough. Keep it quiet if you want yourselves or your technology to survive! Don't antagonise the oil or nuclear cartels by making statements that this technology will put them out of business. It is going to take a long time to get the technology to the mainstream and replace oil imports or nuclear power. By that time, these technologies can be an economic part of the multinational oil and nuclear corporations.
3. To raise one question as to why the SWAT teams, or the 'Men In Black', are so brash in their operations of suppression. With no warning or explanation to the inventors, they act. These actions seem irrational in a country that was founded on freedom of expression. It seems prudent for the level of government controlling these 'black helicopters' and SWAT teams to give warning and reasons for their actions before they act. Please raise this question with your congressman.

Some have said that the 'black helicopters' are part of the Bureau of Alcohol, Firearms, and Tobacco which operates under the US Treasure Department, which in turn operates with the Federal Reserve, which is a private corporation, which operates with the World Bank, over which the US government apparently has no jurisdiction. Thus, they can do what they damn well please.

#### **APPENDIX 1**

Marion Manning, Senator 26th District Engerman,  
Room 2K State Capitol Senate,  
St. Paul Minnesota 55155  
State of Minnesota (612) 296-4171

July 2, 1979

Senator Dave Durenberger  
353 Russell Senate Office Bldg.  
Washington, DC 20510

Dear Senator Durenberger,

Several months ago, a new type of machine was developed by Mr Johnson of Magnatron, Inc. At Elgin, Illinois. where you can see the engine and know that it works. It is not just some wild idea that somebody has.

The reason I am writing you a letter is that a Restraining Order has been placed on Mr. Johnson, the Chairman of Magnatron, Inc., prohibiting him from producing the engine. I have been trying to find out the reason why. Mr. Johnson does not know why either. Would you please send a letter or make a telephone call to the Illinois Attorney General's office and ask what's going on and why they are trying to stop production of this engine? The Attorney General's phone number is (313) 793-3444. Mr Overhand is in charge of the case. I would appreciate your co-operation in this matter.

Sincerely

Marion Manning State Senator  
enc. Pk

#### **APPENDIX 2**

Keeping Inventors Quiet:

Adam Trombly knows about the Secrecy Act. In the early 1980's Trombly and another young scientist, Joseph Kahn, Ph.D., naively believed that the "experts" would welcome their space-energy invention. However, when Trombly and Kahn applied for a patent, the United States Patent Office notified the Department of Defence. Instead of congratulations, Trombly and Kahn received a Secrecy Order. They were ordered not to talk about their invention to anybody, not to write about it, and even to stop working on it. They certainly couldn't tell the media.

If you were an inventor trying to patent an important new-energy discovery. You might receive a Secrecy Order along the lines of the one reproduced here. According to information obtained under the Freedom of Information Act by the Federation of American Scientists, the Pentagon placed 774 patent applications under Secrecy Orders in 1991 (up from 290 in 1979) and 506 of these orders were imposed on inventions by private companies. The government has standing gag orders on several thousand inventions. The following order, issued in the 1980's, was obtained by inventor Ken MacNeil of Georgia and revealed in 1983.

## **SECRECY ORDER**

(Title 35, United States Code [1952], sections 181-188)

**NOTICE:** To the applicant above named, his heirs, and any and all his assignees, attorneys and agents, hereinafter designated principals.

You are hereby notified that your application as above identified has been found to contain subject matter, the unauthorised disclosure of which, might be detrimental to the national security and you are ordered in nowise to publish or disclose the invention or any material information with respect thereto, including hitherto unpublished details of the subject matter of said application, in any way to any person not cognisant of the invention prior to the date of the order, including any employee of the principals, but to keep the same secret except by written consent first obtained of the Commissioner of Patents, under the penalties of 35 U.S.C. [1952] 182, 186.

Any other application already filed or hereafter filed which contains any significant part of the subject matter of the above identified application falls within the scope of this order. If such other application does not stand under a secrecy order, it and the common subject matter should be brought to the attention of the Security Group, Licensing and Review, Patent Office.

If, prior to the issuance of the secrecy order, any significant part of the subject matter has been revealed to any person, the principals shall promptly inform such person of the secrecy order and the penalties of improper disclosure. However, if such part of the subject matter was disclosed to any person in a foreign country or foreign national in the U.S., the principals shall not inform such person of the secrecy order, but instead shall promptly furnish to the Commissioner of Patents the following information to the extent not already furnished: date of disclosure, name and address of the disclose, identification of such part: and any authorisation by a U.S. Government agency to export such part. If the subject matter is included in any foreign patent application for patent this should be identified. The principals shall comply with any related instructions to the Commissioner.

This order shall not be construed in any way to mean that the government has adopted or contemplates adoption of the alleged invention disclosed in this application, nor is it any indication of the value of the invention.

At the conference where he revealed the Secrecy Order, MacNeill advised inventors of new-energy devices to go public: "Get the information or the device out there to enough people so that they cannot stop you."

Note: some of the information quoted here is taken from the book "The Coming Energy Revolution" by Jeane Manning ISBN 0-895290713-2.

## Remembering a Genius Energy Inventor: Dr. Paul Brown (1955-2002)



Photo Courtesy of Ms. Jeane Manning  
Paul Brown accepting Award at COFE-99

I thought it would be years from now that I would be writing about Paul Brown's amazing life and what his friendship has meant to me. His passing on 7th April 2002 in a car crash is a great loss to all of us. I first met Paul in 1983 at a Nonconventional Energy Technology Symposium in Georgia where we both were speakers. At that time, we both liked sharing information and did not believe in proprietary secrets. Paul was the most courageous inventor that I have ever known. When he discovered that "The Moray Device and the Hubbard Coil Were Nuclear Batteries" (published in *Magnets in Your Future*, March, 1987), I was amazed. I remember having dinner with him in Ottawa in 1988 as he explained all of the historical evidence he had uncovered. This was detective work at its finest.

Paul told me about the radiation burns on his hands which he suffered as he learned how to work carefully with Strontium 90 and other materials. He also underwent training and certification to obtain the necessary license for handling radioactive materials. When Paul proceeded to improve upon the resonant nuclear battery work and patent it in 1989 (#4,835,433) as an "Apparatus for Direct Conversion of Radioactive Decay Energy to Electrical Energy," I realized the entrepreneur in Paul was now maturing. At thirty years of age, Paul had merged his small NuCell company with a publicly trading Peripheral Systems, Inc. and began appearing in *Fortune* (Dec. 19, 1988), *Business Week* (Aug. 29, 1988), *Hazmat World* (Dec., 1989), *Nuclear News* (Jan., 1990) and even *The New York Times* (June 24, 1989). Paul also had significant conference presentations at that time such as, "Resonant Nuclear Battery may Aid in Mitigating the Greenhouse Effect" (American Nuclear Society, San Francisco, CA, 1989) and "The Beta Voltaic Effect Applied to Radioisotopic Power Generation" (American Nuclear Society, Nashville, TN, June, 1990).

Little did I know the life-threatening suppression that Paul suffered for inventing an improved, clean source of energy, that was better than any NASA thermoelectric "nuclear" batteries. Every so often a nuclear physicist in the audience would catch on that his battery exceeded the available thermal decay energy, which Paul calculated to include the available angular momentum energy. That is when his 25-year lifespan battery became too much of a good thing for some people. In 1991, Paul explained his disappearance from the business world and public life with a shocking one-page letter he circulated to IECEC speakers through Dr. Pat Bailey. His letter, showing how dangerous this work is, will forever remain etched in my memory (excerpt reprinted below):

"I have been involved with alternate energy since 1978, while still a college student. Over the years I have heard many nightmare stories about people who developed something significant only to be persecuted, harassed, persecuted, and even killed. I was sure that these stories were exaggerated or possibly the result of the inventor's own paranoia or such. Further, I met several inventors whom I felt were their own worst enemies (via fabrications of their imaginations) which confirmed my beliefs.

As time went on, in about 1982, I became involved in work of some significance and received some minor criticism and skepticism that I found to be beneficial as well as practical, but no death threats of any of the other forms of persecution. I built experimental devices, learned things not found in books, filed for patents and in general felt very satisfied with my life, society and the scientific system.

However, things began to change, slowly and alarmingly. The more success I had in my endeavors -- the more I began to attract dishonest and greedy people (I know this now but was unaware of it then). My life became more uncomfortable as time went on but I was not sure of the problem.

In 1987 we decided it was time to let the world know what we were working on and the results we were getting. It was a proud time for me. I thought we were doing the right thing. But this was the real beginning of the worst. Since that February 1987, I or my company have been persecuted by the State Dept. of Health; then the Idaho Dept. of Finance filed a complaint against the company and myself; my license for handling radioactive materials was then suspended for 6 months; I began to receive threats (i.e. 'we will bulldoze your home with your family in it'); then the investigation by the Oregon Dept. of Finance; then the tax man; then the Securities and Exchange Commission; my wife was assaulted; I lost control of my company; my home has been robbed three times and vandalised on four other occasions; twice now I have been accused of drug manufacturing; I lost my home; most recently my mother's car was pipe bombed. With each hardship I strive harder toward successful development of the technologies under my endeavor. But it only seems to get worse.

Someone once said, 'Paranoia is only a heightened sense of awareness.' He was right! It is hard for the average guy to comprehend these disasters happening to selected people. I am here to tell you it is not coincidence. I now understand why some inventors drop out from society.

My advice to you is keep a low profile until you have completed your endeavor; be selective in choosing your business partners; protect yourself and your family; know that the nightmare stories are true.

God speed, Good Luck in your endeavors, and never lose The Faith.

Sincerely,

Paul Brown

(Open Letter to All Working on Alternate Energy-- November 1, 1991)

It took about four more years before Paul would, as he told me later on, "stick his head above water to see if it would get cut off." He said that he had completely dropped the business venture in Oregon because his life was more important to him than money. Furthermore, the arrests and convictions that he endured were groundless harassment, according to Paul. My guess at the time was that they were probably intended to discourage him from disturbing the fossil fuel industry, which at that time, the U.S. was going to war to protect. Only with the subsequent encouragement of friends did he later resume his research and start lecturing again, this time on tritium batteries. When I saw Paul at a 1997 conference in Colorado, he was approached by a couple of businessmen who alerted him to the brand new Bell Labs-Lucent Technologies patent #5,642,014 (June 24, 1997). Called a "Self-Powered Device," the Bell inventors had brazenly referenced Paul's public lecture on the tritium battery concept, which they proceeded to patent. What was also unusual about the application was that it was designed solely for a watch battery that would last 25 years. Instead of going for more powerful designs, that perhaps would disturb major economic controlling interests, Bell Labs chose an almost innocuous application that surely would not displace any existing businesses. To me, this shed a light on the problems Paul suffered in Oregon with "Solving the Worldwide Need for Reliable Cheap Power" as the title of a 1989 article in Business Magazine indicated as his intentions.

In the midst of the tritium research and Paul's inability to buy it in the state where he worked, he accidentally stumbled upon a curious phenomenon in a nuclear handbook. As he looked down a long list of radioactive isotopes which are all made in nuclear reactors, Paul noticed that if he could remove one neutron from their

nuclei, he would transmute each of them into a very-short-lived isotope. This discovery made him very excited and for the next few years, Paul started testing this theory. Not only was it true but the government apparently knew about it right after WW II. (Many scientific labs around the world subsequently confirmed the viability of the photoremediation -Hypercon process). Why bury nuclear waste and endanger everyone nearby for thousands of years, Paul asked, when he could apply photoremediation (using low energy X-rays) and generate electricity too? As another company was formed and started to bring this invention to where Nuclear Solutions is today, Paul and his family had to survive a National Security Agency camp-out at their home for an extended period of time. The NSA kept threatening him and his family with "bringing in the van" if they didn't cooperate. When one young company employee asked an NSA agent what would happen if they just posted the information about nuclear waste treatment on the web in spite of any NSA controls, the agent responded, "We will kill you". (Paul's wife who was there has also confirmed this quote). In terror, they could only imagine whether they would live through the interrogation experience or not. It was fortunate, as Paul told me later, that he made phone calls to at least one or more high level government friends, including one who had connections with the CIA. The intercession between Paul and the NSA, that was facilitated by the third party, was crucial to allowing Paul and his company to continue with their completely peaceful intention of eliminating nuclear waste.

Paul Brown was, and always will be, a hero in my eyes. He was also the first recipient of the "Integrity in Research Award" at our Conference on Future Energy in 1999, which made him very happy. The picture of Paul accepting that award can be found on our institute's <http://users.erols.com/iri/Pauleulogy.htm> website, where we also proudly offer the 200-page "Collected Writings of Paul Brown, Ph.D." (IRI #808) as a memorial to his genius. Paul has published extensively on a wide variety of topics including atmospheric electricity, variable reluctance alternators, propellant-less propulsion, alternates to mass-gain at light velocities, gravity and residual electric force, besides the nuclear topics mentioned above. Wired magazine produced a great article about Paul in Feb., 1999 called "Nuking Nukes" that is posted at the web location: <http://www.wired.com/wired/archive/7.02/mustread.html?pg=19> (and can be e-mailed, faxed, or printed for free, according to the website).

Nuclear Solutions, the company which he founded, [www.nuclearsolutions.com](http://www.nuclearsolutions.com) has confirmed their intention to carry on Dr. Brown's lifetime of service and discovery. Their main product, clean electricity generation plants utilizing photoremediation of nuclear waste, is well-documented on their website. It is a publicly trading company whose stock will inevitably soar, just as Paul did with all of his achievements.

Keeping the faith,

Thomas Valone, MA, PE  
President  
Integrity Research Institute  
1220 L St. NW #100-232  
Washington, DC 20005  
202-452-7674, 800-295-7674  
FAX: 301-513-5728  
<http://www.integrityresearchinstitute.org>

### ***My Opinions:***

The following paragraphs give my opinions on the advantages, disadvantages and the likelihood of successful replication by the average DIY enthusiast, of each device covered. It should be stressed that while it has been the aim to present *facts* in all of the other areas of this set of documents, the following information is **not** fact but merely my personal opinions.

### **Aerial Pick-up systems**

<b>Device:</b>	<b>Moray's aerial system.</b>
<b>Inventor:</b>	Thomas Henry Moray
<b>Power:</b>	High, several kilowatts.
<b>Advantages:</b>	Operates day and night No moving parts Later versions worked with internal (or no) aerial

**Disadvantages:** Silent in operation  
Little or no input power needed  
Probably uses mildly radioactive material  
**Building:** May need an aerial and earth  
Uses valves which are not well defined  
May need radioactive material  
**Conclusion:** Very little specific constructional information available  
Might well be interesting as a long-term investigation

**Device:** **Tesla's aerial system.**  
**Inventor:** Nikola Tesla  
**Power:** Not known, but probably reasonable  
**Advantages:** Operates day and night  
Some versions have no moving parts  
Several options for converting the energy to normal electricity  
Looks to be a very simple arrangement  
Little or no input power needed  
**Disadvantages:** Needs an aerial plate and an earth  
Needs a vertical space in which to operate  
Has to operate in a fixed location  
**Building:** Appears straightforward  
The higher the plate and the larger the aerial, the greater the power available  
**Conclusion:** Might well be interesting to check out

**Device:** **Prentice's aerial system.**  
**Inventor:** Frank Prentice  
**Power:** Three kilowatts output for 0.5 kilowatts input.  
**Advantages:** Operates day and night  
No moving parts  
Silent in operation  
Simple construction  
**Disadvantages:** Uses a very long aerial wire  
Needs a location where the very large aerial may be located  
Has to operate in a fixed position  
**Building:** Appears very straightforward  
Aerial wire may be expensive  
**Conclusion:** Very possible for a fixed location.

**Device:** **Plauston's aerial system.**  
**Inventor:** Hermann Plauston  
**Power:** Very high, many options, large systems over 100 kW output.  
**Advantages:** Operates day and night  
No moving parts  
Silent in operation  
Simple construction  
Can pick up energy from the wind  
**Disadvantages:** Very detailed patent information with many alternative methods of construction  
Uses long aerial wires and possibly metallic, spiked balloons  
Needs a location where the very large aerial may be located  
Has to operate in a fixed position  
**Building:** Appears very straightforward with lots of details provided in the patent  
Aerial wire may be expensive  
**Conclusion:** Very possible for a fixed location with many options for improvements

**Device:** **Roy Meyers' pick-up system.**  
**Inventor:** Roy Meyers  
**Power:** High and scalable  
**Advantages:** Operates day and night



No moving parts  
Silent in operation  
Very simple construction  
Detailed patent information

**Disadvantages:** An earth connection is recommended  
Has to face North - South at all times

**Building:** Appears very straightforward

**Conclusion:** Very possible for a fixed location with options for increasing the output power

**Device:** [Harold Aspden's Electrical Power Generating Apparatus](#)

**Inventor:** Harold Aspden

**Power:** Presumably high

**Advantages:** Operates day and night

No moving parts

Silent in operation

Very simple construction

Harold is still available to answer questions

**Disadvantages:** I am not aware of anybody who has constructed one

**Building:** Appears very straightforward

**Conclusion:** Well worth an experiment.

**Device:** [The Pyramid Generator](#)

**Inventor:** Flavio Thomas

**Power:** Low

**Advantages:** Operates day and night

No moving parts

Silent in operation

Very simple construction

Interesting field of research

**Disadvantages:** Needs exact compass alignment

**Building:** Appears very straightforward

**Conclusion:** Well worth building and experimenting with.

## Generators

**Device:** [Edwin Gray's Power Tube](#)

**Inventor:** Edwin V. Gray snr.

**Power:** Very high, can drive 80 horsepower electric motor

**Advantages:** Simple construction

Essentially fuel-less operation

Has been replicated by amateurs

Detailed information now available

Mobile device

**Disadvantages:** Uses a spark gap which will cause wear

Needs high voltage to operate, so care is needed

Not quite silent in operation

Uses two batteries so is not particularly lightweight

**Building:** Appears very straightforward with lots of details provided

**Conclusion:** Realistic device to construct with a high output potential

**Device:** [Pavel Imris's Optical Electrostatic Generator](#)

**Inventor:** Pavel Imris

**Power:** High, can drive 100 40-watt fluorescent tubes

**Advantages:** Reasonably simple construction

Output power more than 40 times the input power

**Disadvantages:** Needs constructional ability

**Building:** Reasonable amount of detail provided and much test data



**Conclusion:** Realistic device to construct with a high output potential

**Device:** **The Muller Motor**

**Inventor:** William Muller.

**Power:** High, output can be hundreds of amps

**Advantages:** Simple construction

High output power / input power ratio

Reasonably compact

Almost silent in operation

Mobile device

**Disadvantages:** Uses very powerful and expensive magnets

Needs care to avoid injury when handling magnets of this power

Some attempts to replicate it have failed

**Building:** Appears straightforward but needs good craftsmanship

**Conclusion:** Realistic device to construct with a high output potential

**Device:** **The RotoVerter**

**Inventor:** Hector Torres

**Power:** About 1 kW maximum

**Advantages:** Reasonably simple construction

Output power considerably greater than the input power

Reasonably compact

Device is just about mobile

High probability of successful construction

Good for getting to understand Radiant Energy capture

**Disadvantages:** Uses two expensive motors

Motors may become unavailable at a later date

Device is somewhat heavy and of fair size

Produces some noise when operating

Needs battery and inverter for mobile use

Battery needs charging from mains or via an expensive solar panel

**Building:** Appears straightforward but needs considerable setting up and tuning

Hector states that the input power should never be taken from the output power.

**Conclusion:** Reasonable medium output device to construct

**Device:** **The Thestatika**

**Inventor:** Paul Baumann

**Power:** Under 1 kW

**Advantages:** The whole of the output is free-energy as it is self-powered

Apparently simple construction

No input power needed

Reasonably compact

Device is just about mobile

Reasonable chance of successful construction

**Disadvantages:** Output is not staggering

Long-term reliability is not certain

Full construction details have not yet been published

As far as I know, nobody has replicated it successfully

**Building:** With our present knowledge, it should be possible to build it

The book "Homemade Lightning" by R.A. Ford should help (ISBN 0-07-021528-6)

**Conclusion:** Reasonable medium output device to research

**Device:** **The HMG system**

**Inventor:** Nikola Tesla

**Power:** Very high

**Advantages:** Compact, portable unit

Apparently simple construction

Reasonable chance of successful construction

**Disadvantages:** Generates 12,000,000 volt pulses and so calls for exceptional care

**Building:** As far as I know, nobody has replicated it successfully, but it is not widely known  
Construction should be straightforward

**Conclusion:** Extreme caution is needed due to the very high voltage produced  
High-power device which is potentially lethal

**Device:** **The Tesla coil pick-up**

**Inventor:** Nikola Tesla

**Power:** Very high

**Advantages:** Compact, portable unit  
Apparently simple construction  
Reasonable chance of successful construction

**Disadvantages:** High voltages are used and some parts may be expensive  
As far as I know, nobody has replicated it successfully, but it is not widely known

**Building:** Construction should be straightforward  
Extreme caution is needed due to the high voltage used

**Conclusion:** High-power device which is probably worth investigating

**Device:** **The Tesla longitudinal waves pick-up**

**Inventor:** Paulo and Alexandra Correa

**Power:** Potentially high

**Advantages:** Compact, portable unit  
Simple construction  
High chance of successful construction  
No moving parts (except possibly the Tesla Coil pulsers)

**Disadvantages:** High voltages are used and some parts may be expensive

**Building:** Construction should be straightforward  
Extreme caution is needed due to the high voltage used

**Conclusion:** Probably worth investigating

**Device:** **The Kawai motor**

**Inventor:** Teruo Kawai

**Power:** Low, but presumably scaleable

**Advantages:** Output power measured at three times the input power  
Good constructional details in the patent

**Disadvantages:** Construction calls for professional-quality metalwork  
As far as I know, nobody has replicated it successfully, but it is not widely known

**Building:** Construction should be straightforward for a mechanical engineer

**Conclusion:** Interesting low-power device, likely to be very reliable

**Device:** **The Lafonte Motor / Generator**

**Inventor:** Butch Lafonte

**Power:** Low, but presumably scaleable

**Advantages:** Simple construction  
Designer available for queries  
Can be used with an existing electrical circuit without using any additional power

**Disadvantages:** The overall design is probably not over-unity

**Building:** Construction should be straightforward

**Conclusion:** Interesting low-power device, likely to be very reliable

**Device:** **The MEG ("Motionless Magnetic Generator")**

**Inventor:** Tom Bearden and four others

**Power:** Under 1 kW

**Advantages:** Self-powered  
No moving parts, so likely to be very reliable  
Silent in operation

**Disadvantages:** Light and portable  
Some replication attempts have failed while others succeeded  
The best construction calls for custom materials used for the yoke

**Building:** Construction should be straightforward

**Conclusion:** Interesting mid-power device, likely to be very reliable

**Device:** [The Acoustic-Magnetic Power Generator](#)

**Inventor:** Dan Davidson

**Power:** Medium

**Advantages:** Self-powered  
No moving parts  
Portable and compact  
Patent gives considerable detail

**Disadvantages:** As far as I am aware, nobody has replicated this device

**Building:** Appears simple

**Conclusion:** This is a variation on Bearden's MEG device

**Device:** [The Continuous Electrical Generator](#)

**Inventor:** Alberto Molina Martinez

**Power:** Scalable

**Advantages:** Self-powered  
No moving parts, so likely to be very reliable  
Silent in operation  
Portable

**Disadvantages:** Construction should be reasonably straightforward

I am not aware of any replication attempts to date

The information comes from a patent application rather than a full patent.

**Building:** Construction should be straightforward

**Conclusion:** Interesting device, likely to be very reliable

**Device:** [The Solid State Electric Generator](#)

**Inventor:** Graham Gunderson

**Power:** Medium

**Advantages:** Self-powered  
No moving parts, so likely to be very reliable  
Silent in operation  
Portable

**Disadvantages:** Construction should be reasonably straightforward

None known to date (the information comes from a patent application rather than a full patent).

**Building:** Construction should be straightforward

**Conclusion:** Very interesting device indeed, likely to be very reliable

**Device:** [The Phi-Transformer](#)

**Inventor:** Alex Frolov (?)

**Power:** Perhaps 1 kW

**Advantages:** Might be made self-powered  
Very simple low-tech construction  
Easily understood  
Light and portable

**Disadvantages:** The motor will wear out eventually

**Building:** Construction should be straightforward

**Conclusion:** Very interesting mid-power device, likely to be very reliable

**Device:** [The Adams motor](#)

**Inventor:** Robert Adams

**Power:** Low to medium power

**Advantages:** Output power some seven times more than the input power  
Simple construction  
Easy to understand  
Portable

**Disadvantages:** Requires good quality bearings

**Building:** Construction should be straightforward

**Conclusion:** Interesting device along the lines of the Muller Motor

**Device:** **Faraday's Homopolar Generator**

**Inventor:** Michael Faraday

**Power:** High, but at very low voltage

**Advantages:** Very high current output, far higher than the input power  
Simple construction  
Easy to understand  
Portable

**Disadvantages:** Has been used for electrolysis of water  
Very low output voltage  
Difficult to get reliable low-resistance brushes

**Building:** Construction hinges on the brush construction

**Conclusion:** Interesting device but difficult to make reliable brushes

**Device:** **Sweet 's VTA**

**Inventor:** Floyd Sweet

**Power:** Medium

**Advantages:** Self-powered  
Mains power at the correct AC frequency  
No moving parts  
Portable and compact

**Disadvantages:** Difficult to perform the initial 'conditioning' of the ferrite slab  
Conditioning can be lost through a strong magnetic pulse nearby (lightning etc.)

**Building:** Might be difficult to get the ferrite slab, otherwise simple

**Conclusion:** Very interesting device with good output, but can be disrupted

**Device:** **Hubbard's 'Atmospheric Power Generator'**

**Inventor:** Alfred Hubbard

**Power:** High

**Advantages:** Self-powered  
No moving parts  
Portable and compact

**Disadvantages:** As far as I am aware, nobody has replicated this device

**Building:** Appears simple on the surface

**Conclusion:** Lack of exact construction details makes this an investigation project

**Device:** **Brown's 'Battery'**

**Inventor:** Paul Brown

**Power:** Patent shows low-power version

**Advantages:** Self-powered  
No moving parts  
Portable and compact

**Disadvantages:** Essentially, a variation on Alfred Hubbard's device  
As far as I am aware, nobody has replicated this device  
Calls for obtaining radioactive salts

**Building:** Appears simple on the surface

**Conclusion:** The 100 watt version supposedly operated erratically

**Device:** **The Colman / Seddon-Gillespie 'Battery'**

**Inventor:** Harold Colman and Ronald Seddon-Gillespie

**Power:** 1 KW  
**Advantages:** Self-powered  
No moving parts  
Portable and compact  
Incredible 70-year life  
Produces no radioactivity when not in use and is shielded when in use  
**Disadvantages:** Calls for construction of a chemical mixture in a quartz tube  
**Building:** Reasonably achievable with a little ingenuity  
**Conclusion:** Very, very impressive device with almost unlimited potential

**Device:** **Coler's "Magnetstromapparat" device**  
**Inventor:** Hans Coler  
**Power:** Low - in the 300 mA range  
**Advantages:** Self-powered  
No moving parts  
Portable and compact  
**Disadvantages:** As far as I am aware, nobody has replicated this device  
Very difficult to get operating  
Very easy to disrupt its operation  
**Building:** Appears very simple  
**Conclusion:** Proves free-energy pick-up  
Not a practical device for powering essential equipment

**Device:** **Coler's " Stromerzeuger " device**  
**Inventor:** Hans Coler  
**Power:** Medium  
**Advantages:** Low input power  
No moving parts  
Portable and compact  
**Disadvantages:** I know of only one person attempting to replicate this device  
Very little constructional information available  
**Building:** Appears simple, but not much to go on  
**Conclusion:** Interesting, but impractical at this point in time

**Device:** **The "Romag" and "Mini-Romag" Generators**  
**Inventor:** Not known  
**Power:** Low: 25 watts and over  
**Advantages:** Self-powered  
Portable and compact  
Reasonable constructional details available  
**Disadvantages:** Calls for constructional materials not usually readily to hand  
Not replicated by many people  
**Building:** Medium level of difficulty  
**Conclusion:** A possible research project

**Device:** **The Cook Generator**  
**Inventor:** Daniel Cook  
**Power:** Medium  
**Advantages:** Self-powered  
Portable though long and heavy  
Full constructional details available in the patent  
Very simple materials used  
**Disadvantages:** Construction may be fairly expensive  
As far as I know, this device has never been replicated by anyone  
I can see almost no way that this device could operate as claimed  
**Building:** Very simple  
**Conclusion:** Might be worth building out of curiosity, if it worked it would be brilliant

**Device:** [Pyramid Generators](#)  
**Inventor:** Flavio Thomas  
**Power:** Low  
**Advantages:** Self-powered  
Simple low-tech construction  
Few details available on converting to drive electrical equipment  
Silent, with no moving parts  
**Disadvantages:** Needs to be aligned magnetically (unless a cone shape is used)  
**Building:** Very simple  
**Conclusion:** Very interesting research tool for the Zero-Point Energy field

**Device:** [Self-Powered Semiconductor Power Pack](#)  
**Inventor:** Michael Ognyanov  
**Power:** Low  
**Advantages:** Self-powered  
Simple low-tech construction  
Silent, with no moving parts  
**Disadvantages:** Requires casting of a semiconductor pad  
**Building:** Straightforward  
**Conclusion:** Very interesting device, worth testing

**Device:** [The 'OceanStar' Electricity Generator](#)  
**Inventor:** Muammer Yildiz  
**Power:** High  
**Advantages:** Supposedly self-powered  
Simple low-tech construction  
Is said to be able to be scaled up to power a whole house  
**Disadvantages:** Noisy in operation  
Unproven device which is not well described  
weighs a considerable amount  
**Building:** Reasonably straightforward  
**Conclusion:** Probably worth waiting to see if it gets into production or the Patent granted.

### [Battery systems](#)

**Device:** [Bedini's Battery pulsers](#)  
**Inventor:** John Bedini  
**Power:** Low  
**Advantages:** Charges one or more batteries while running  
Portable and compact  
Full constructional details available also unlimited enthusiast support  
Very simple materials used  
Good as a school project due to its simplicity and visual effect  
John's original device has run for years  
**Disadvantages:** Rotor can spin so fast that the magnets break free, causing damage unless housed  
Ideally, magnetic rotor bearings are needed  
**Building:** Straightforward, with unlimited help available  
**Conclusion:** Captures the interest of most people, but can't power anything serious

**Device:** [Tesla's Four-Battery Switch](#)  
**Inventor:** Nikola Tesla  
**Power:** High  
**Advantages:** Charges itself while powering external loads  
Portable  
Full constructional details available

**Disadvantages:** Components readily available  
Has been successfully replicated recently  
Requires four batteries  
If built to the original design, the switching needs a small motor with brushes  
Some attempts to replicate this with semiconductor switching have not worked

**Building:** Straightforward

**Conclusion:** A serious device which may need careful research

**Device:** [Bedini's Three-Battery Switch](#)

**Inventor:** John Bedini

**Power:** High

**Advantages:** Charges itself while powering external loads  
Portable  
Components readily available

**Disadvantages:** Requires three batteries

**Building:** Reasonably straightforward

**Conclusion:** This is a variation on the Tesla four-battery switch above

**Device:** [Ron Cole's One-Battery Switch](#)

**Inventor:** Ron Cole

**Power:** Medium / High

**Advantages:** Charges itself while powering external loads  
Portable  
Components readily available

**Disadvantages:** Requires large capacitors  
To my knowledge, not fully proven and replicated

**Building:** Straightforward

**Conclusion:** This is a variation on the Tesla four-battery switch

## Magnet Motors

**Device:** [Howard Johnson's Magnet Motor](#)

**Inventor:** Howard Johnson

**Power:** Medium / High

**Advantages:** No input power needed  
Portable and compact  
Can drive a standard electricity generator

**Disadvantages:** Requires powerful magnets which may be expensive  
Requires custom magnets made to a special shape  
Requires mu-metal which is expensive  
I am not aware of anybody replicating this motor

**Building:** Reasonably straightforward

**Conclusion:** This could be an interesting research project

**Device:** [The Camus Magnet Motor](#)

**Inventor:** Nelson Camus

**Power:** About 300 watts

**Advantages:** No input power needed  
Portable and compact  
Components readily available

**Disadvantages:** To my knowledge, not fully proven and replicated

**Building:** Reasonably straightforward

**Conclusion:** Good potential if it is made to work

**Device:** [The Bedini Magnet Motor](#)

**Inventor:** John Bedini

**Power:** Probably low unless powerful magnets are used  
**Advantages:** No input power needed  
Portable and compact  
Components readily available  
Power could be increased by using multiple rotors on one shaft  
Very simple construction  
**Disadvantages:** To my knowledge, not fully proven and replicated  
**Building:** Very easy  
**Conclusion:** Good potential if it is made to work

**Device:** **The Ecklin Magnet Motor (and the Brown/Ecklin Generator)**  
**Inventor:** John Ecklin  
**Power:** Medium  
**Advantages:** Low input power needed  
Portable and compact  
Components readily available  
Simple construction which does not use exotic materials  
**Disadvantages:** I am not aware of many replications of this device  
**Building:** Straightforward  
**Conclusion:** Good potential for a practical device

**Device:** **The 'Invention Intelligence' Magnet Motor**  
**Inventor:** Invention Intelligence  
**Power:** Medium  
**Advantages:** No input power needed  
Portable and compact  
Components readily available  
Simple construction which does not use exotic materials  
**Disadvantages:** I am not aware of any replications of this device  
**Building:** Straightforward  
**Conclusion:** Good potential for a practical device

## Vehicle systems

### **(A) Hydrogen boosters:**

**Device:** **Many different systems**  
**Inventor:** Many  
**Advantages:** Runs off the vehicle's generator  
Can be made without great difficulty  
Cleans up previously deposited soot  
Reduces pollution emissions dramatically  
Raises the miles-per-gallon performance substantially  
Reduces running costs substantially  
**Disadvantages:** It may be difficult to find spare room in the engine compartment  
**Building:** Straightforward  
**Conclusion:** Excellent choice for people who travel long distances each week

### **(B) The Ram-Wing:**

**Device:** **The Ram-Implosion Wing**  
**Inventor:** Robert Patterson  
**Advantages:** Completely passive with no moving parts  
Easy construction  
Overcomes wind-blast from passing Heavy Goods Vehicles  
Reduces fuel consumption  
Reduces running costs



**Disadvantages:** It only works at the higher road speeds  
**Building:** Straightforward  
**Conclusion:** Excellent choice for people who drive fairly fast

### (C) High mpg. carburetors:

**Device:** **Various patents from 200+ inventors**  
**Inventor:** Many different inventors  
**Advantages:** Adds on to almost any vehicle  
Construction not particularly difficult  
Reduces fuel consumption dramatically  
Reduces running costs  
Reduces pollution emissions  
**Disadvantages:** Some designs may need the help of a metal-working company  
**Building:** Not particularly difficult  
**Conclusion:** Should be considered seriously by people who drive long distances

### (D) Pulsed electrolysis:

**Device:** **Water Fuel Cell**  
**Inventor:** Stanley Meyer  
**Advantages:** High volume gas production for very small power input  
Several cells in parallel can produce enough gas to run a car from water alone  
Uses no electrolyte - just tap water  
Reduces running costs  
Zero pollution emissions  
Has been replicated recently  
**Disadvantages:** Very difficult to keep a cell tuned to exactly the critical frequency  
The zero pollution emissions may cause the vehicle to fail some US emission tests  
Uses high voltage for maximum efficiency  
**Building:** Not particularly difficult  
**Conclusion:** Probably too difficult a project for most people

**Device:** **Mateiro's pulsed electrolysis Cell**  
**Inventor:** Paulo Mateiro  
**Advantages:** High volume gas production for low power input  
Shown powering a lawnmower  
Uses no electrolyte - just tap water  
Zero pollution emissions  
Uses low voltage  
**Disadvantages:** The original information is no longer on the web  
I am not aware of anybody replicating it  
**Building:** Not difficult  
**Conclusion:** An interesting system possibly worth investigating

**Device:** **Puharic's pulsed electrolysis system**  
**Inventor:** Henry Puharic  
**Advantages:** High volume gas production for low power input  
Considerable detail presented in his patent  
**Disadvantages:** The actual production figures are unknown although it is 115% efficient  
I am not aware of anybody replicating it  
**Building:** Medium difficulty  
**Conclusion:** An interesting system not unlike Stanley Meyer's system

### (E) Running a vehicle engine on water alone:

**Device:** [Charles Garrett's carburettor](#)  
**Inventor:** Charles Garrett  
**Advantages:** Simple construction with good information  
Compact device  
Operation of the original witnessed by several people  
It could certainly act as a hydrogen booster system  
**Disadvantages:** It is by no means certain that this device can produce enough gas to work  
I am not aware of anybody replicating it  
**Building:** Reasonably straightforward  
**Conclusion:** Doubtful that this will work as more than a booster

**Device:** [Bob Boyce's electrolysis cell](#)  
**Inventor:** Bob Boyce  
**Advantages:** Easily understood system  
Compact device  
Known to work well  
Zero fuel costs and only water vapour as an emission  
Not difficult or expensive to construct  
Advice still available from Bob  
**Disadvantages:** Running a vehicle on water alone is hated by the oil industry tycoons  
There will be rust problems unless some parts are replaced with stainless steel  
**Building:** Reasonably straightforward  
**Conclusion:** Doubtful that this will work as more than a booster

**Device:** [Peter Lowrie's electrolysis cell](#)  
**Inventor:** Peter Lowrie  
**Advantages:** Easily understood system  
Compact device  
Zero fuel costs and only water vapour as an emission  
Known to work well  
Not difficult to construct  
Uses three 'Archie Blue' electrolyser cells in series, and so is well-proven  
Advice still available from Peter  
Operates self-powered with output power far, far higher than the input power  
Uses standard alternator to give electrical output much higher than the input  
**Disadvantages:** Running a vehicle engine on water alone is hated by the oil industry tycoons  
There will be rust problems unless some parts are replaced with stainless steel  
The semiconductors used are expensive due to their high current-handling needs  
This system is best used with stationary engines used to drive generators  
The exact circuit details have not yet been released  
Peter is selling these units commercially, initially in Australia only  
**Building:** Reasonably straightforward  
**Conclusion:** Excellent system

**Device:** [The Joe Cell](#)  
**Inventor:** Anonymous Australian called 'Joe'  
**Advantages:** Very effective in running engines  
Compact device  
Zero fuel costs and only water vapour as an emission  
Not difficult to construct  
**Disadvantages:** Requires careful setting up with pre-treated water  
Engine timing needs to be advanced some fifty degrees, which may be difficult  
Not an enormous amount of information available on the device  
It is said that the cell can be disrupted by strong magnetic fields  
**Building:** Reasonably straightforward  
**Conclusion:** Very interesting system worth experimenting with

**Device:** [Stanley Meyer's water-injection systems](#)

**Inventor:** Stanley Meyer  
**Advantages:** No gas produced outside the cylinders  
Superbly safe to use  
Zero fuel costs and only water vapour as an emission  
Considerable constructional details are contained in the patents  
**Disadvantages:** I am not aware of anybody who has replicated this  
There will be rust problems unless some parts are replaced with stainless steel  
Engineering metalwork will be required to construct the various components  
**Building:** Not particularly simple  
**Conclusion:** Excellent system

**Device:** [The 's1r9a9m9' water-injection system](#)  
**Inventor:** American mechanic  
**Advantages:** No gas produced outside the cylinders  
Superbly safe to use  
Zero fuel costs and very little water vapour as an emission  
Considerable constructional details have been provided  
Fairly simple conversion  
High mpg due to exhaust being passed through the water tank  
**Disadvantages:** I am not aware of anybody who has replicated this  
I am not aware of anyone who has seen this vehicle in operation  
There will be rust problems unless some parts are replaced with stainless steel  
Spark plug wear is much increased, although cheap plugs are recommended  
Replacements have to be found for the prototype's relays as they are obsolete  
**Building:** Very simple  
**Conclusion:** If genuine (becoming less and less likely), this is an excellent system

**Note:** The [HydroStar](#) and [HydroGen](#) manuals available on the web, show how to modify a vehicle to run on water alone. The consensus of expert opinion is that neither system can possibly produce enough hydrolysis gas to allow any engine to run. If you decide to follow their advice and do actually get an engine to run using either system, please let me know. Until that time, I suggest that you consider these sets of information as of general interest only.

### Inert Gas Engines

**Device:** [The Papp and Britt Engines](#)  
**Inventor:** Josef Papp and Robert Britt (two different engines)  
**Advantages:** No input  
No exhaust  
Completely self-contained and self-powered  
Considerable constructional details have been provided  
Fairly simple conversion of existing engines  
**Disadvantages:** I am not aware of anybody who has replicated this  
Requires automotive engineering skills to modify the engine  
It is felt that there is not quite enough information for easy replication  
The Papp engine may need the gas mix replaced at frequent intervals.  
**Building:** Requires metal-working skills  
**Conclusion:** Incredible engine if it can be reproduced.

### Other systems

**Device:** [Cold Fusion](#)  
**Inventor:** Various  
**Advantages:** Clean power output with minimal power input  
**Disadvantages:** I am not aware of anybody who has replicated this as a practical device

**Building:** The system is still in the laboratory stage of investigation  
**Conclusion:** Probably too early yet, with inadequate information as yet  
Possible future system

**Device:** **Moller's Atomic Hydrogen Generator**  
**Inventor:** Irving Langmuir  
**Advantages:** Clean power output  
**Disadvantages:** The system is still in the laboratory stage of investigation  
Probably a non-mobile system in the early stages of development  
**Building:** Probably too early yet, but check the JL Naudin site for current progress  
**Conclusion:** Possible future system