

# *A Practical Guide to 'Free Energy' Devices*

Part D6: Last updated: 16th July 2006

Author: Patrick J. Kelly

## **5. If hydrogen can be efficiently split, then energy is available when it is recombined**

Stanley Meyer, Henry Puharich, Paulo Mateiro, Charles Garrett, Archie Blue, Bob Boyce, Peter Lowrie, etc.

Hydrogen is a dangerous substance to handle. It's molecules are small enough to permeate through materials generally thought to be suitable for containing gases. It can make metals brittle. It is considered a 'green' fuel because when it is burnt with oxygen, it does not produce carbon dioxide. While this is true, it is not the whole picture. Hydrogen burnt with oxygen produces a flame inconveniently hot and in mobile applications, you have to carry the oxygen around as well as the hydrogen. Unfortunately, the flame temperature can be lowered conveniently by burning the hydrogen in air, which also dispenses with the need to carry the oxygen around. Burning hydrogen in air or an oxygen/air mixture, produces nitrous oxide which is a major pollutant - and if you do that, it is no longer a 'green' fuel (although it produces less pollution than petrol or diesel).

If you opt for a ready-mix of hydrogen and the oxygen it needs to burn, the resulting mix is explosive and highly dangerous. This difficulty is overcome if water is carried and split into a gas mixture only when needed for burning. An additional possible power source is "flash-steam" where water vapour is converted to a much larger volume of steam very suddenly.

**The material presented here is for information purposes only. Experimenting with hydrogen and/or a mixture of hydrogen and oxygen is highly dangerous and you do so entirely at your own risk. Patrick Kelly does not recommend you to do so and he disclaims any responsibility should you decide to do so against his advice.**

We need to stop burning fossil fuels. If we do so, it leaves us with two problems, namely, a way to generate power to run our electrical equipment and heat or cool our homes, and a way to power our vehicles. In this document, we will consider the question of powering vehicles.

There are two main options. The first is to achieve a reduction in the amount of fossil fuel burnt. The second is to eliminate the use of fossil fuel altogether. Both have been achieved. As an example of the first option, consider a car powered by a petrol (gasoline) engine. In the average car, only 35% or so of the fuel is burnt in the cylinders of the engine, the remaining 65% burns in the catalytic converter or is pushed, unburnt, out of the exhaust pipe as major pollution.

### **Reducing the fuel used:**

It is possible to reduce the amount of fuel used, by utilising any or all of the following :

1. Improving the quality of the burn.
2. Reducing the amount of fuel in the cylinder.
3. Introducing water vapour into the cylinder.
4. Improving the quality of the spark.
5. Improving the streamlining of the vehicle

1. The burn quality can be improved dramatically by replacing some or all of the air drawn into the engine, by a mixture of hydrogen and oxygen. This can be done by sacrificing a small amount of engine power to drive an electrolyser to split water into the hydrogen/oxygen mix needed, passing it through a safety 'bubbler' and feeding the gas into the air intake of the engine. This causes a dramatic improvement to the burn, increases the power of the engine, reduces the pollution and improves the miles per gallon achieved.

2. The fuel mix can be made leaner. If more air is used, the engine will run hotter. If a hydrogen/oxygen mix is used, then there is a general improvement all round. If the vehicle has computer control of the fuel/air mix, it is necessary to add an extra circuit to prevent the computer injecting more fuel to offset the leaner mix required.

3. Adding water vapour to the air intake can give a 25% improvement in the miles per gallon.

4. If the power of the spark is increased by adding extra circuitry to the electrical system, the fuel burn is improved. However, this tends to lead to greater plug wear. The "FireStorm" plug gives a major improvement in burn quality and is likely to go into commercial production in winter 2005.

5. If driving speed reaches 60 mph for much of the mileage covered, then a "Ram Wing" clamped on top of the car can give a major improvement in fuel consumption through reduced wind pressure. Details of this are shown later in this document.

If using hydroxy gas to improve the burn quality and improve the mpg of a vehicle, no timing adjustments are normally necessary. However, all recent cars in the USA are fitted with an Electronic Mixture Controller and if nothing is done about that, a decrease in mpg may actually occur as the Controller may start pumping more fuel into the engine when it sees a change in the quality of the exhaust. Good information on how to deal with this problem can be found at the web site <http://better-mileage.com/memberadx.html> which includes details of how to deal with the Controller.

### **Eliminating fossil fuels altogether:**

If no fossil fuel is used, then some practical details have to be dealt with. It will necessary to retard the engine timing as hydrogen burns 1000 times faster than conventional fuels. Retarding the timing of recently constructed vehicles by as much as 35 degrees is very difficult as they are usually computer controlled and do not provide that degree of spark control. The Yahoo Group 'hydroxy' gives information and help for anybody who wishes to take this further and can be found at <http://groups.yahoo.com/group/hydroxy>

It is difficult to run a vehicle with water as the only fuel but it has been done by several people. **Daniel Dingle** of the Philippines has succeeded but has not yet released details of how he does it. **Stanley Meyer** ran two different vehicles using a different technique for each. He obtained patents for both systems. **Peter Lowrie** has run an internal combustion engine on gas from electrolysis of water. **Herman Anderson** patented a device for running any engine on hydrogen. He then went on to use an on-board electrolysis system to provide the hydrogen for his device. He also used micron-sized water mist using a pond fogger and fed that into the engine via a standard vehicle propane regulator. His car is a 1971 LTD V-8 on which he got 38 miles per gallon running on water. A 'WaterFuel1978' Group member, an American mechanic who, at this time, prefers to be known by his e-mail ID of "**s1r9a9m9**" states that he has run a vehicle on water alone for some 30,000 miles and has released most of the details to the Group, however, this vehicle has not been shown to anyone and no pictures have been released. **Bob Boyce** has powered his entries in boat racing events using just water as a fuel, but with batteries charged on shore. He has also powered car engines by 'pulsed' electrolysis driven by the alternator of the vehicle receiving the gas (construction details in the 'D9.pdf' document of this set).

It is also highly likely that others have done this as well. **Juan Aguero** has patented a system for running internal combustion engines using a combined hydrogen/oxygen/steam mixture. As he states the specific amounts of fuel mix needed for a 1400 cc engine, it is highly likely that he determined the amount by running an engine of that capacity. Reading **Henry Puharich's** water-splitting patent, suggests that he actually ran an engine on it rather than just proposed the method. **Charles Garrett** was reported to have run his car on water alone, although I strongly suspect that his patent does not disclose the full details of how he did it.

So, how did they do it and why can't we buy their systems for our own use? The answer is not technical but is financial. In Britain, successful people have the bulk of their income taxed at 40%. They then buy a car which has an 'import tax' of some 15% on it and on top of that, Value Added Tax at 17.5%. Then they are charged 'Road Tax' of about £160 per year (85% of which is not used on building roads). Then they have to buy petrol or diesel at about £4 per gallon (roughly three times the cost of fuel in the USA) of which somewhere between 55% and 85% is tax. If they drive into London, they are charged an extra £8 for the privilege of using the roads for which they have already been overcharged. To summarise: every year, the government takes a very large sum of money from motorists. How do you think they would react to motorists using water instead of fossil oil would they be for it or against it? Also, one oil company has just announced that their profit in the last year amounted to \$3,000,000 PER HOUR and it is only one of many such companies. How much do you think any one of those companies would pay to stop a water-powered car going into production?

So what has happened to the inventors? Stanley Meyer ran his VW car on several of his pulsed electrolysis cells for four years. He then developed a sophisticated water plasma injection system and drove a converted dune buggy from coast to coast across USA on 28 US gallons of water. He was reported to have just received an assurance of production funding when he died suddenly and unexpectedly. That was very convenient for the oil companies.

Daniel Dingle has not released any details of his system and has not attempted to go into production, so he has had almost no influence on the economic scene. It has been declared illegal in the USA to manufacture or sell water-powered cars. Nobody cares much about hydrogen-assisted cars as the users still have to go on buying fossil fuels from the oil companies.

Peter Lowrie has produced enough gas by electrolysis to run an engine and he and others are making adjustments to his, and other, electrolysis systems under test. As their developments have not yet reached the production stage, they have

been left reasonably alone. Bob Boyce of USA, reached the full-use stage of development. His workshop was broken into repeatedly, some of his electrolyzers were stolen, some were smashed. This continued until no more electrolyzers remained in his workshop. Then, his workshop was broken into again but nothing was taken and nothing smashed - get the picture? Guess why "s1r9a9m9" does not want excessive publicity. He has come up with another system, where hot water is fed into the engine through a carburettor and with the use of a 110V inverter to boost the sparks, the engine runs well. It is quite possible that the motive power in his system is flash-steam rather than any form of electrolysis occurring inside the cylinders. All of the details which he has released to date are in the "D13.pdf" file which forms part of this set of documents. Most of the patents mentioned above are also included in these documents.

It has been suggested that if you want a car which runs with water as the only fuel, then you will have to make it yourself. This may well be the case at this time. I hope that you can see that it can be done in at least three different ways. Let me fill you in on some of the basic information on the processes.

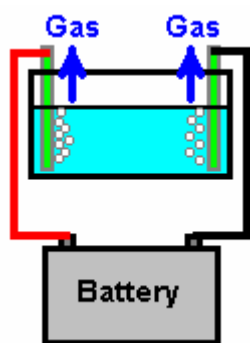
### **Electrolysis:**

There are two main types of electrolysis; 'basic' and 'pulsed'. "Basic" electrolysis was described by Faraday many years ago. It consists of placing two electrodes in an electrolyte solution and passing a current through the solution. An electrolyte solution is just some water with a little additive of acid, salt or some other useful substance which improves the current flow without being used up in the process. Basic electrolysis is very easy to achieve but not very efficient.

"Pulsed" electrolysis is very much more efficient with enormously reduced input power requirements but it is difficult to achieve and maintain the optimum frequency setting. Stanley Meyer achieved it. Bob Boyce achieved it. You might achieve it but it is definitely the difficult option.

### ***Straight Electrolysis:***

This technique has been known for thousands of years and appears very simple. Faraday described the method and defined the gas output for 100% efficiency of the process. Members of the 'egaspower' Group have achieved 200% to 300% of Faradays theoretical maximum output per watt of input power. Straight electrolysis works like this:

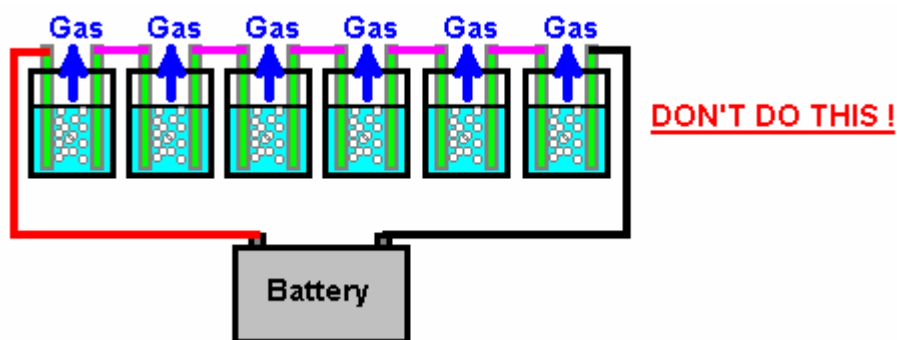


Here, a current flows through the liquid inside the electrolysis cell, moving from one plate to the other. The current breaks the bonding of the water molecules, converting the  $H_2O$  into hydrogen H and oxygen O. There are various forms of hydrogen and oxygen and mixtures of the two. H on its own is called "monatomic" hydrogen, and given the chance, it will join with another H to form  $H_2$  which is called "diatomic" hydrogen. The same goes for the oxygen atoms. The monatomic variety has four times the energy and just under 1% of it mixed with air, is capable of powering an engine without using any fuel oil, while it takes about 4% of the diatomic gas mixed with air to do the same job.

If the liquid in the electrolyser is distilled water, then almost no current will flow and almost no gas will be produced. If you add a little battery acid to the water, the current and gas production increase enormously. Putting acid in the water is a bad idea as it gets used in the process, the acidity of the water keeps changing, the current keeps changing, the acid attacks the electrodes and unwanted gasses are given off. Putting salt in the water, or using seawater, has nearly the same effect with poisonous chlorine gas being given off. Instead of using these "electrolytes" it is much better to use a "catalyst" which promotes the electrolysis without actually taking part in the chemical process. The best of these are Sodium Hydroxide ("Red Devil lye" in the USA) and even better still, Potassium Hydroxide.

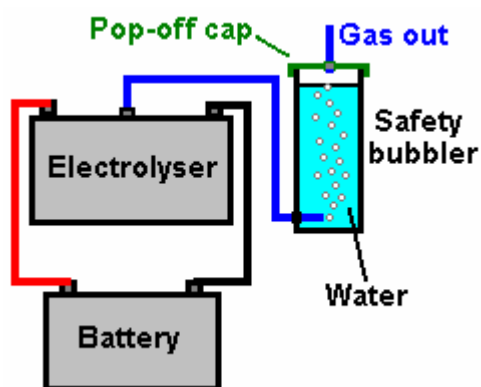
The process of electrolysis is most unusual. As the voltage applied to the plates is increased, the rate of gas production increases (no surprise there). But once the voltage reaches 1.24 volts, there is no further increase in gas production with increase in voltage. If the electrolysis cell produces 1 litre of gas per hour with 1.24 volts applied to the electrodes, then it will produce exactly 1 litre of gas per hour with 12 volts applied to the electrodes. Even though the input power has been increased nearly 10 times, the gas output remains unchanged. So it is much more effective to keep the voltage between

the electrodes to 1.24 volts or some value near that. As there is a small voltage drop due to the material from which the electrodes are made, in practice the voltage per cell is usually set to somewhere between 1.4 to 2.0 volts.



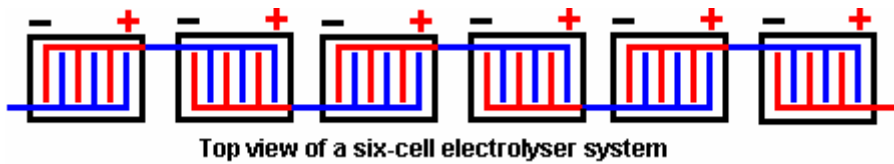
The electrolyser shown here produces six times as much gas for exactly the same input power. This is a serious gain in efficiency. As all of the cells of this electrolyser are identical, each has approximately 2 volts across it when a 12 volt battery is used. The amount of gas produced depends directly on the amount of current passing through the cells. As they are in series, the same current passes through all of them. For any given battery voltage and electrode spacing, the current is controlled by the amount of catalyst added to the water. The liquid in the electrolyser cells is called the 'electrolyte'. In practice, there is a distinct advantage in having a large surface area for each electrode. There is a strong tendency for bubbles of gas to remain on the surface of the electrodes and impede the electrolysis process. If there were enough bubbles on an electrode, it would not actually touch the electrolyte and electrolysis would stop altogether. Many methods have been used to minimise the problem. The electrode plates are normally made from 16 gauge 316L stainless steel and it is recommended that there be between 2 and 4 square inches of plate area on every face of every electrode for each amp of current passing through the cell. Some people have tried placing an ultrasonic transducer underneath the plates to vibrate the bubbles off the plates. Archie Blue and Charles Garrett make the engine suck its input air through the electrolyser and relied on the air drawn through to dislodge the bubbles. Some people use piezo electric crystals attached to the plates to vibrate the plates and shake the bubbles free, others use magnetic fields, usually from permanent magnets.

As indicated in the drawing above, you MUST NOT perform electrolysis with the gas escaping freely, unless you are out of doors with very good ventilation. Hydrogen and hydrogen/oxygen mix gasses are HIGHLY dangerous, easily ignited and can easily injure or kill you. They must be treated with a high degree of respect. You need to keep the amount of gas held at the top of each cell to a minimum, and ALWAYS use a bubbler as shown here:



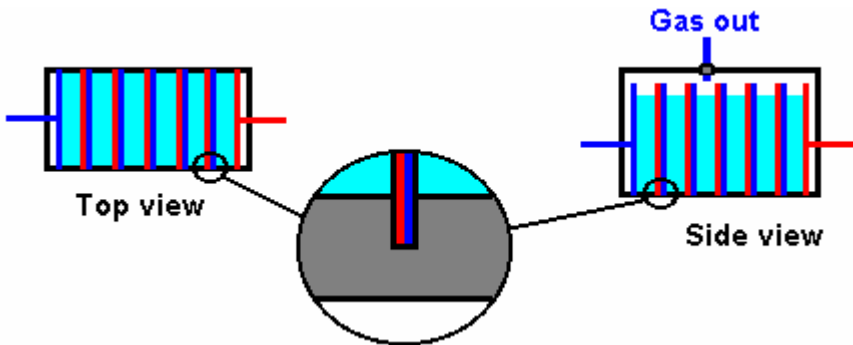
The deep water in the bubbler stops any flashback reaching the electrolyser and should the gas at the top of the bubbler be ignited by some accident, then the tightly-fitting cap should blow off harmlessly. If equipment of this nature is being installed in any vehicle, NO component containing hydrogen or "hydroxy" gas must ever be placed inside the passenger compartment. The engine compartment should be used to house this equipment or, if you really must, the boot (trunk) and no pipe containing gas should run through any part of the passenger area. Staying alive and uninjured is much more important than reducing fuel consumption.

There are many different way of constructing electrolysis equipment. A fairly conventional electrical set-up is shown here:



Three plates are used for each electrode and the cells are connected in series. This is a perfectly good arrangement and it has the advantage that the plates can be submerged deeply in the electrolyte, the cells are fully isolated from each other and they can be positioned in convenient locations scattered around the engine compartment. Also, the gas from each cell can be drawn through the electrolyte of the other cells, and this helps to dislodge gas bubbles and improve the operating efficiency of the system.

It is possible to simplify the electrolyser housing as shown here:



Here, the outer casing is slotted to receive the electrode plates. The build accuracy needs to be high as the electrode plates are expected to form an almost watertight seal to create six separate cells inside the housing. In this diagram, the central electrode plates are shown in red for positive and blue for negative voltage connections. The plates are just single sheets of stainless steel and to a quick glance, it looks as if the central plates do nothing. This is not so. Because the electrolyte is not free to move between compartments, it produces the same electrical effect as the arrangement shown here:

### An alternative arrangement



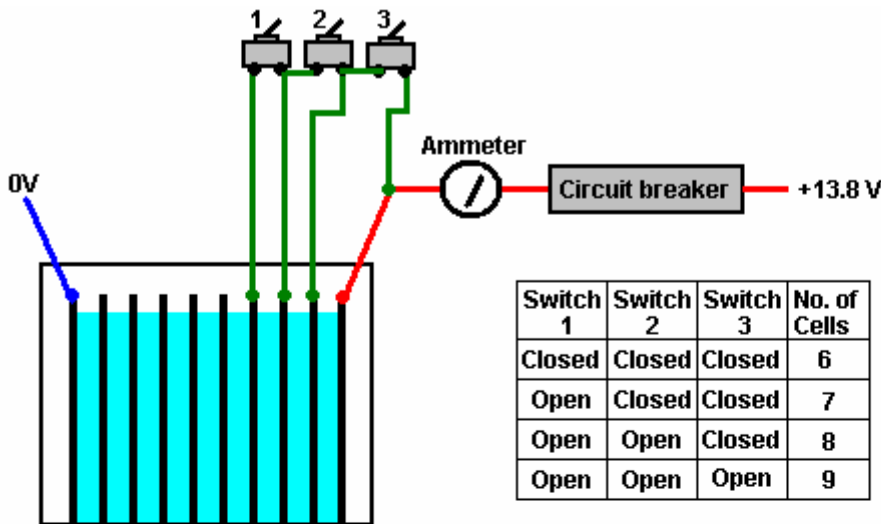
While this is the same electrically, it requires the production and slotting of five additional plates. Each extra plate is effectively redundant because the space between the internal pairs is empty (wasted space) and one steel plate is just wired directly to the next one. As the plates are wired together in pairs, there is no need to have two plates and a connecting wire - a single plate will do. The reason for pointing this out in detail is because it is quite difficult to see how the standard arrangement is connected electrically with the opposite sides of a single plate forming part of two adjacent cells and the electrical connection between those two cells.

When straight electrolysis is being used, the rate of gas production is proportional to the current flowing through the cells. With 12 volt systems, the current is usually determined by the concentration of the electrolyte and its temperature. When an electrolyser is first started, it usually has a fairly low temperature. As time goes by, the electrolysis raises the temperature of the electrolyte. This increases the current flowing through the electrolyser, which in turn, heats the electrolyte even more. This causes two problems. Firstly, the gas production rate at start-up is lower than expected as the electrolyte is not as hot as expected. Secondly, when the electrolyser has been going for some time, a temperature runaway effect is created where the current gets out of hand.

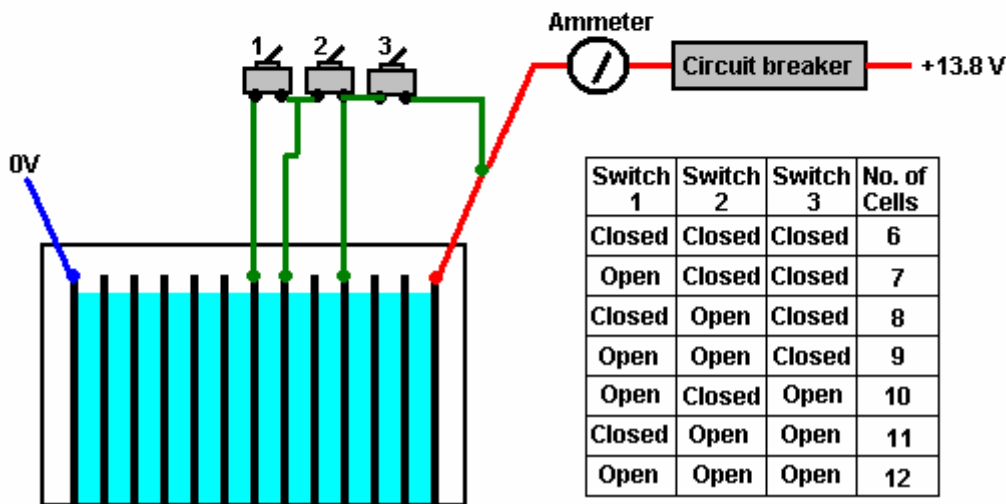
There are various solutions to this situation. One is to accept that the gas production will be low in the early stages of each run, and adjust the concentration of the electrolyte so that the maximum running temperature gives exactly the design current through the electrolyser. This is not a popular solution. Another solution is to use an electronic "Mark/Space Ratio" circuit to control the current. This rather impressive name just means a circuit which switches the power to the electrolyser ON and OFF many times each second, more or less the same as a dimmer switch used to control lighting levels in the home. This solution places an ammeter to show the current, and a Mark/Space Ratio control

knob on the dashboard of the vehicle, and the driver lowers the current manually if it starts to get too high.

Another, very effective alternative is to add in extra electrolysis cells. As well as controlling the current, this raises the efficiency of the gas production. This can be achieved in various ways. One option is to install extra cells with a heavy duty 12V switch across them. When the switch is closed, the cell is starved of current and effectively is not operational at all. Heavy duty switches of this kind can be bought in ship chandlers at reasonable cost as they are used extensively in boating for switching engine and lighting circuits in power boats and sailing yachts. An alternative is to use a high powered semiconductor to replace the switch and use cheap, low power switches to control the semiconductors. This last option adds unnecessary circuitry but it holds out the possibility of automating the process where the electronics circuit switches the cells in and out automatically depending on the current being drawn by the electrolyser. Firstly, using heavy duty switches, the arrangement could be like this:



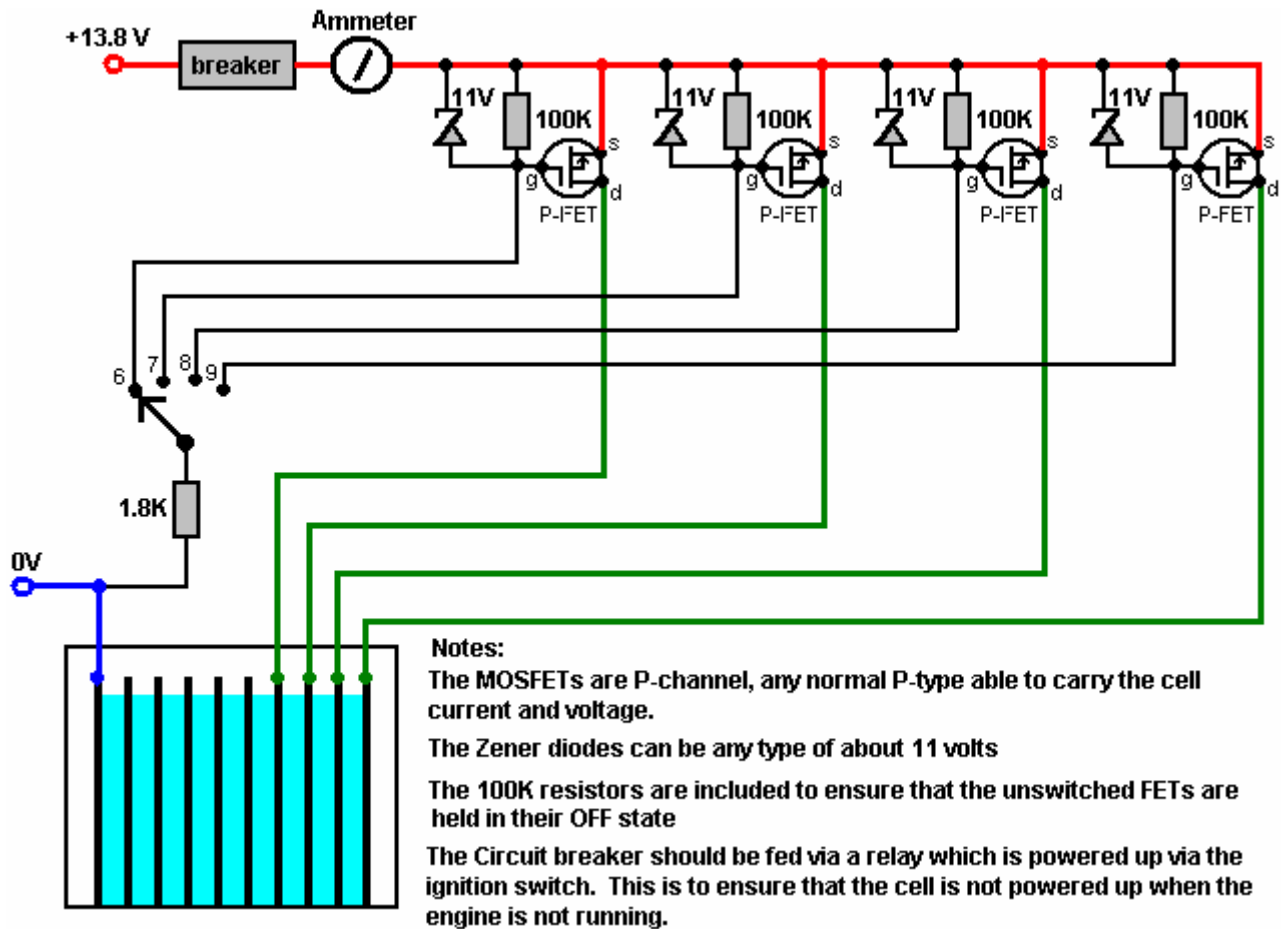
OR



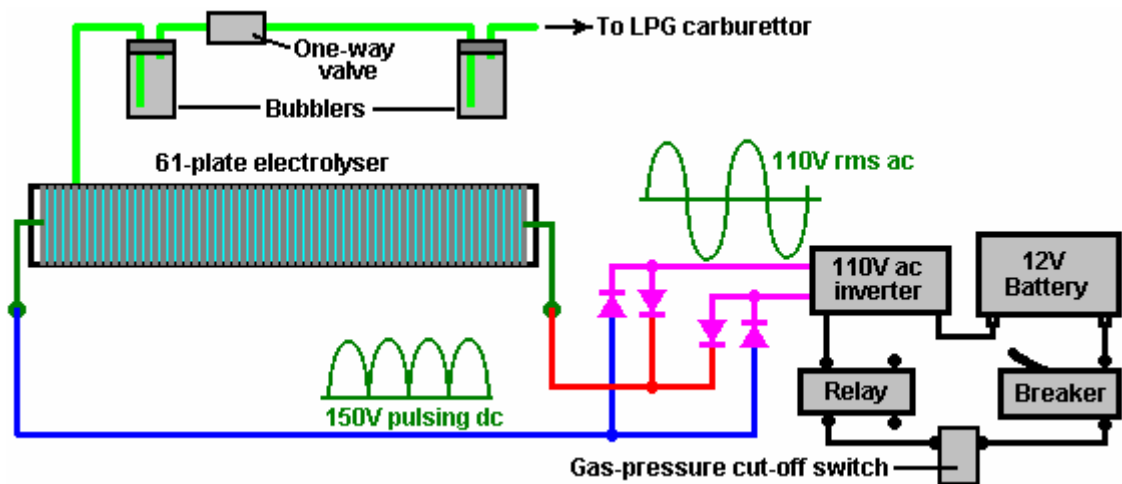
In the first option, the arrangement is very simple with three switches adding in three additional cells - one switch per cell, very easy to understand and operate. The second arrangement uses the same three switches but it allows twice as many extra cells to be switched in. However, the switching arrangement is more complicated when driving along with one switch having to be opened and another having to be closed.

With the electronics option, the switch arrangement inside the vehicle is very straightforward with a single rotary switch mounted on the dashboard being used to select the number of additional electrolysis cells to be used. The diagram here shows the switching for three additional cells, but the circuit can be continued for more cells if desired. The only practical

limit is in the rotary switch where twelve positions is the normal maximum for a standard wafer switch. That would give eleven additional cells which far more than would be realistic in practice. In fact, the three additional cells shown is probably as much as would be used if this method were adopted.



Bob Boyce has used the multi-plate series-cell arrangement to great advantage with electrolyser containing 61 separate plates. This forms 60 self-contained, interconnected cells within the electrolyser and he places approximately 2 volts across each cell by using a 300 watt, 110V ac sine-wave inverter driven from a 12V battery. The timing circuit of the inverter is altered to give any chosen frequency from 600 Hz to 800 Hz so that the resonant frequency of the cell can be matched. Bob then uses a bridge rectifier to convert the 110V ac to 150V pulsing DC before applying it to the electrolyser as shown here:



The recommended treatment for the 6" x 6" stainless steel electrode plates in this electrolyser is as follows. Do not put acid on the plates, instead, clean them with sandpaper, scoring the surface in a criss-cross pattern. This both cleans the

surface and provides more surface area than the flat surface does. Next, rinse the plates off with distilled water and place them in a dilute solution of Sodium Hydroxide. Leave them in the solution for a few days. This creates a film on the plates and conditions them for high-performance use. Rinse the plates off and replace the solution with a new batch. The plate spacing is set at 3 mm (1/8 inch) as this is a good compromise between minimum power and reasonable bubble clearance.

It is important that the plates form a nearly watertight seal with the sides and base of the electrolyser housing and that there is no hole below the waterline in any plate. If the electrolyte has a path between any two cells, they will cease to be in series, and effectively, the operation of one of the cells is lost or impaired.

While 316L grade stainless steel is the normally recommended plate material for electrolyzers, Ronald Classen recommends Aluma-Ti as an even better material. Aluma-Ti is a vacuum-degassed, interstitial-free steel containing columbium and titanium and it can be used in temperatures up to 1,400<sup>0</sup>F (800<sup>0</sup>C) It is commonly used in the automotive industry for parts which are exposed to great heat and corrosive environments. One common product using Aluma-Ti is the "TorcTite" exhaust and tailpipe clamps available in the USA in the "NAPA Autoparts Store" chain. Ronald used the 16 inch straps which are 3 inches wide and cost about \$15 each. He remarks that this material is completely non-magnetic, does not corrode and more importantly, when used in electrolysis, the gas bubbles do not remain on the plates but break away immediately. Smaller plates can therefore be used if Aluma-Ti is the chosen material.

All right, now that the main principles have been covered, lets look at some examples. Here is a picture of an electrolyser built by Chris, taken from his 300-picture description of his experiments with electrolysis which can be found at the web site [http://www.oupower.com/index.php?dir=\\_My\\_Projects/\\_Over\\_Unity\\_Related\\_Projects/Electrolysis](http://www.oupower.com/index.php?dir=_My_Projects/_Over_Unity_Related_Projects/Electrolysis)



The case is constructed from perspex. The gas output is taken from either nipple with the other one capped. The electrical input is via the wires led through the middle of the top of the case. Not all electrolyzers are built this way.

Take the case of the "Hydro-boost" design found at <http://www.angelfire.com/ak5/energy21/hydroboost.htm> which has been around for several years. This is what the site says:

### ***The First Tests:***

The first vehicle this system was on was a 1985 AMC Jeep. The vehicle belonged to a friend of mine who was developing this system at the same time that I was. He got an astounding 60-70 mpg when driving on the open road and 40-50 mpg driving in the city.

My first few personal tests were on a 1983 AMC Eagle SX4 4WD. The problem was that the car was in such a poor state of repairs that I never had a consistent period of time to test it properly. The one time I did test it on a long trip, I forgot to read the odometer when I arrived at my destination! The only fact I can give concerning the mileage was that I drove from Erie, PA to Hagerstown, MD on approximately one half a tank of fuel. I drove 357 miles using a minimum 9 gallons of gasoline (my tank registered just below the halfway mark). This would figure to 39.7 mpg. Even figuring the use of 10 gallons means I made 35.7 mpg. My Eagle normally got 15 mpg on a highway! On this trip I had to have been getting at



least 35 mpg. But where was the 60 mpg highway that my friend's Jeep had obtained? Our engines were identical and yet I got lower mileage.

The only difference I could find was that he had used his air conditioning pump to force the produced gases into the top of his air filter. I had thought instead of sacrificing the air conditioner, I would cut the line from the PVC valve to the carburettor, insert a T-connector, and allow the vacuum from the engine to suck the gases in. I discovered that using a pump to force the gases into the engine seems to work better.

The second test I used it on for a long trip in my Eagle also was botched up. I had changed from galvanised bolts to bolts labelled 'zinc' to use as electrodes. After a 100 mile drive to Buffalo, NY I found my electrodes had rusted to the point the water was murky and no gasses were being produced. I did not replace them and ran the rest of the tank out sightseeing at Niagara Falls. I did get a pleasant surprise when I refilled the tank. Even though the device was running for only 100 miles of that tank of gas, my overall mileage (including the 2/3 of a tank the electrolysis unit was not functioning -which again, normally meant 15 mpg highway) still indicated I had got 23 mpg! Remember, this was with the device only running for 2 hours of driving. The mileage for this trip must have been quite good in order to register 23 mpg overall.

The next test came after I finally got a chance to have the system work by forcing the gas into the top of the carburettor with a pump. I shared the idea with another friend of mine who put a windshield wiper pump into the top of the electrolysis tank and used it to force the gases into the top of the air filter.

The results are 67 mpg highway, 47 mpg city in an 8 cylinder 350 (5.75 litre) engine running a 4WD pick up! The other truck it was installed on was a 4WD pick up with a 351 engine. Both trucks report the same mileage.

### ***Advantages and Disadvantages:***

There are a few minor drawbacks with the electrolysis unit. It requires maintenance from time to time. The first drawback is that the electrodes will need replacement periodically. Normally this will be after every two tanks of gas. Every two tanks is not a bothersome thing when the mileage gain increases the distance/time you go between tanks. A typical vehicle that has a 20 gallon fuel tank and gets 15 city mpg will go 300 miles before it needs to be refuelled. Using the electrolysis unit, the same type of vehicle may get 47 city mpg (as the two trucks cited previously). If such a vehicle is getting 47 city mpg, it will go a distance of 940 miles before the tank needs to be refilled.

The second drawback is that the unit will also need to be cleaned out after every two tankfulls. As the electrodes deteriorate, they deposit a black, wet, powdery sludge at the bottom of the electrolyser. Just rinse it out with water. The benefits are numerous. Mileage increase; more money in your pocket; the engine burns cooler which could result in a longer engine life; a little more power has been noted in our test vehicles; less fuel being burned implies cleaner emissions and a healthier environment.

### ***Lets Build It:***

The parts list for the basic unit is simple. To make a typical 8.5 inch tall unit, you need the following PVC pipe pieces/parts (I have used schedule 40 PVC but any type will do):

- A length of 4 inch pipe; a 4 inch end cap; a 4 inch clean out and plug.
- 8 X 3/8 inch galvanised carriage bolts; 8 galvanised nuts; 2 wing nuts;
- 4 washers to go with the carriage bolts;
- A 2 inch length of threaded hollow rod (the rod used in making lamps through which they run the electric cord is perfect);
- A small 12 volt windshield wiper fluid pump;
- A length of wire such used in running extra brake lights;
- Some battery acid (you can get this from an old car battery);
- Circle (and maybe spade) 'crimp' connectors that will allow you to put a circle on the end of your wire so they can easily slip over the ends of the carriage bolts; and
- A tomato paste can (the inside coating on the can seems to prevent deterioration during the electrolysis).

The cost depends on how many parts you can find lying around. Made from all new parts the cost will vary between \$20 and \$30.

### ***Step 1. Where to Mount It:***

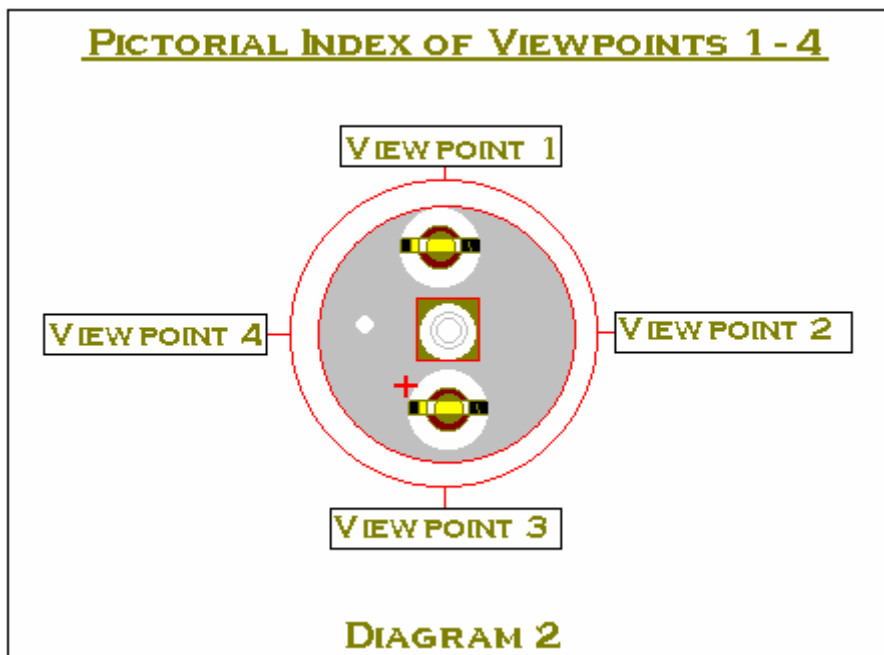
The first thing to do is decide where you will be able to mount this device in your engine compartment. Find a place in your vehicle's engine compartment where you will be able to mount a 10 inch high, 4 inch wide device that will not be in the way of the bonnet when it is in its closed position.

Be creative in the way you will mount this device - all car engine compartments are different. The completed unit will need to be inserted vertically into the compartment; stay in the upright position; be firmly mounted so as to eliminate splashing of the liquid inside; be positioned such that the closed hood will not pinch off the air hose coming from the top of the unit; and facilitate easy removal for periodic maintenance.

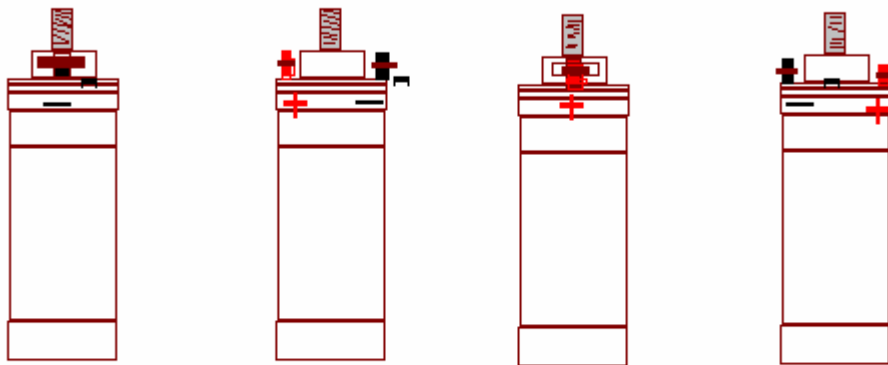
My father found a good way to mount his. He obtained a six inch diameter 'elbow' connector piece of drain pipe; bolted it (hole upwards) to the side wall; bolted a 1/4 X 2 X 10 metal strip sticking up out of the top of the elbow; inserted his electrolysis tank into the elbow; and then put a hose clamp around the metal strip and the electrolysis tank.

## ***Step 2. Construction:***

Look over diagrams 2- 4 until you feel you have a good idea of what the completed unit will look like. This will facilitate the following of the building instructions. It is a lot easier than it sounds.



**VIEWPOINT 1-4 SIDE VIEWS**



**VIEWPOINT 1**

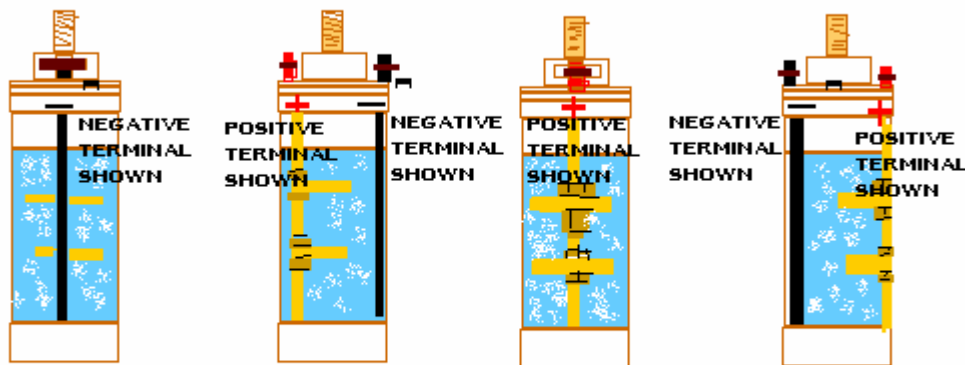
**VIEWPOINT 2**

**VIEWPOINT 3**

**VIEWPOINT 4**

**DIAGRAM 3**

**VIEWPOINTS 1-4 SEEN AS IF MAIN TANK IS TRANSPARENT**



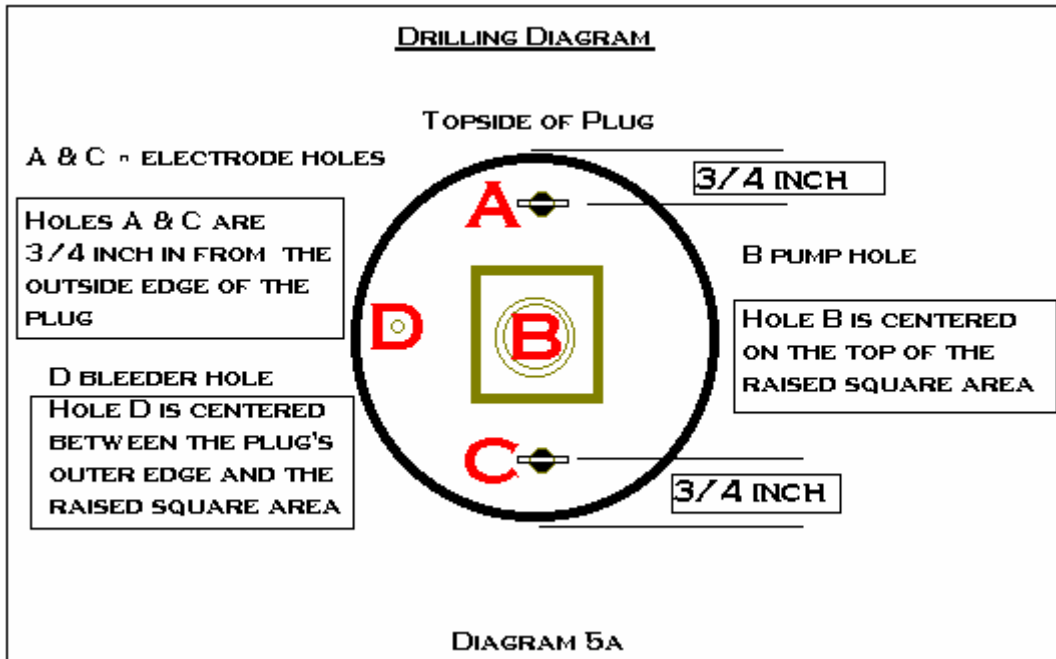
**VIEWPOINT 1**

**VIEWPOINT 2**

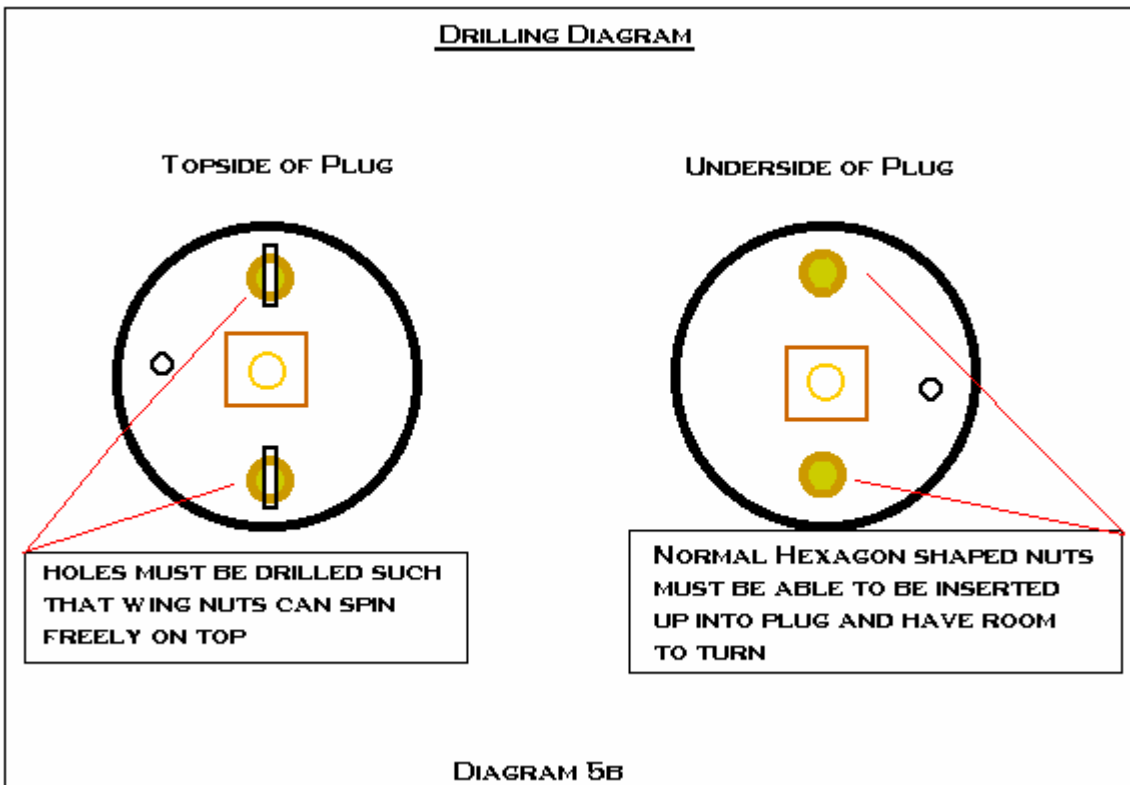
**VIEWPOINT 3**

**VIEWPOINT 4**

**DIAGRAM 4**



Refer to Diagram 5a and drill holes on either side of the square raised area on the PVC plug that will allow the carriage bolts to be threaded into the holes. But take care that the hole is far enough in so that a nut affixed to the bolt will be able to fit into the underside of the plug without getting caught on its rim. (see Diagram 5b).

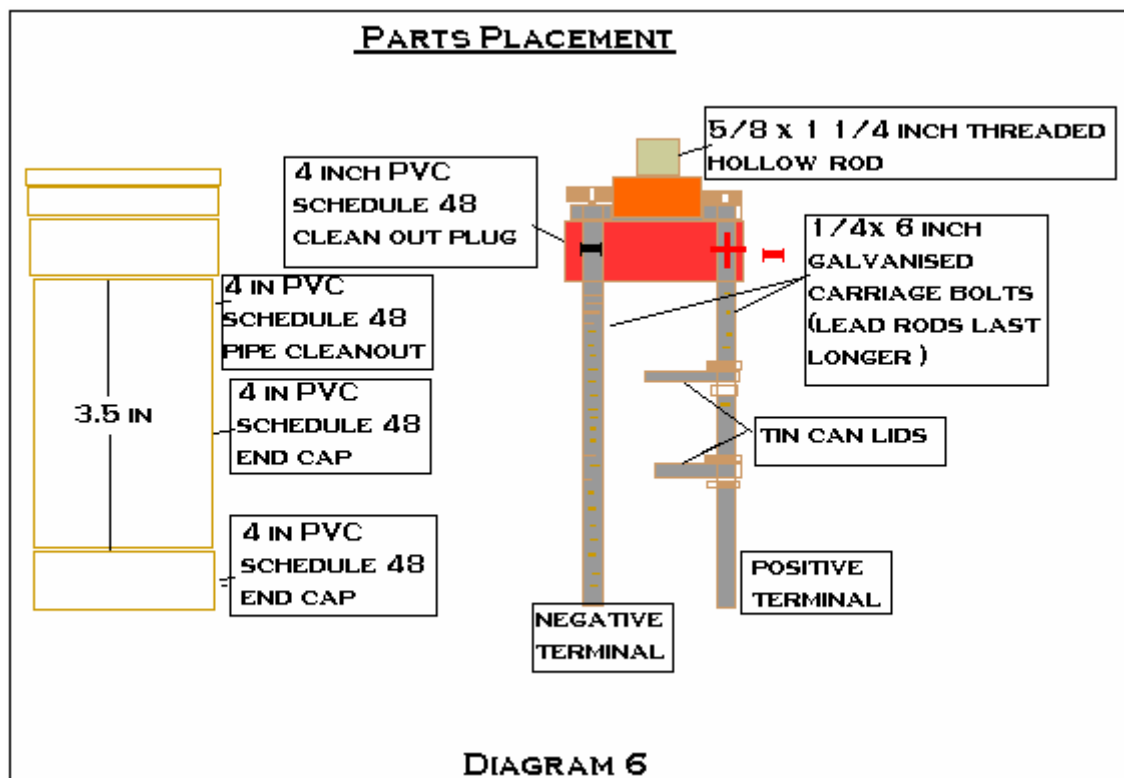


Use a red indelible marker to designate one of these holes as the positive terminal. Drill a hole in the top of the raised square on the plug such that the threaded hollow rod can be threaded into it. Drill a 1/8 inch 'bleeder hole' (as in diagram 5a) in the top of the cap on the side of the square that has not already been drilled through. This bleeder hole acts as an air intake for the pump to operate with.

To insert your positive electrode, thread a nut down a little more than an inch from the end of one of the carriage bolts. Put a washer down on top of this. Thread this carriage bolts into the hole made for it in the plug. Run it up through so that the nut and washer are pressed tightly against the inside of the plug's cap.

This should leave an inch extending beyond the top of the plug. Put a washer down on the top of the newly exposed end of the bolt and thread a nut down to hold the washer tightly to the lid. Follow this by a wing nut (I had to grind the tips of the wing nuts down a little to allow them to tighten down on the bolt without running into the side of the square raised area of the plug).

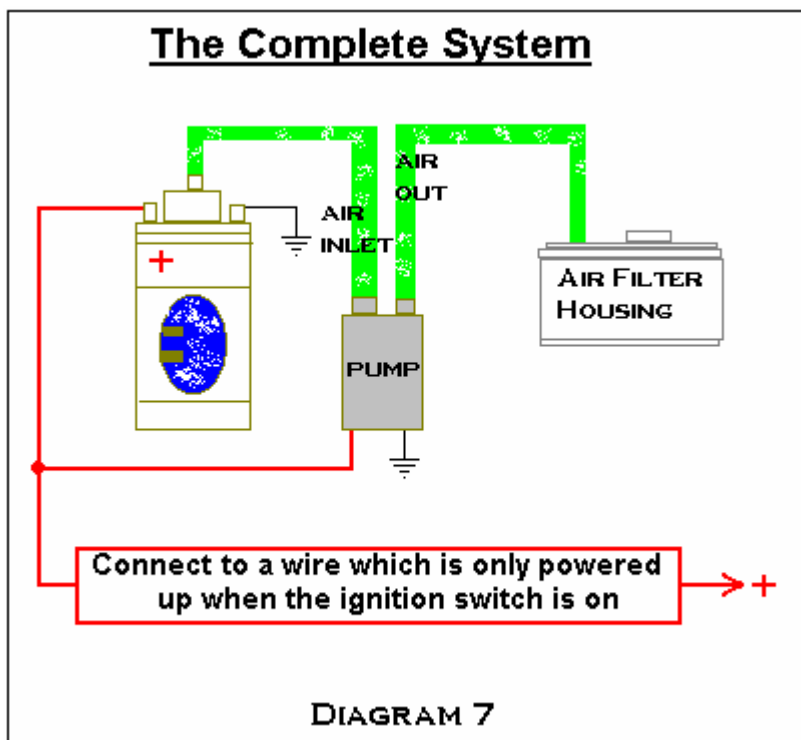
The top and bottom of the tin can must now be prepared for use. I find the hydrogen tends to collect better around a sharp edge. Therefore, take the top and bottom of the tomato paste can (I tried using stainless steel discs and found the tomato paste can lids lasted longer because they did not deteriorate as fast) drill holes in them that will allow them to be threaded/slid up the carriage bolts (see Diagram 6 concerning the tin can lids).



Also drill many holes in these lids such that a grid pattern is produced (these holes may also be made by using a nail to punch through the lids), hydrogen bubbles will form around the perimeters of all of these holes. Since these lids give the hydrogen more edges to collect on, a greater volume of hydrogen seems to be produced. I tried using more than two plates and found the amount of hydrogen did not seem to increase further.

To make the negative electrode, thread a nut 3/4 of the way down the other carriage bolt's length, slide/thread a tin can lid down onto it, follow the can lid with a nut. Tighten the lid onto the bolt using the two nuts. Slide/thread the other can lid onto the bolt in the same manner such that there will exist a one inch gap between the top nut of the lid farthest down and the bottom nut of the top lid. Make sure both lids are facing the same direction on the bolt such that the whole assembly will be able to be fit into the electrolysis tank.

Repeat the procedure you used on the positive electrode to insert the negative electrode into the hole that was drilled, and marked, for it in the plug. Screw a 2 inch length of the threaded hollow rod into the top hole. Make it flush with the inside of the plug.



Familiarise yourself with Diagram 7 so as to better understand the following instructions. Mount the windshield wiper pump in the engine compartment. Connect the ground wire of your new pump to the frame. Find a wire that is live only when the ignition is on (I unplugged the modular plug from my car's wiper pump and tested which wire on this was hot with a probe) and connect the hot wire from the pump to it. Sometimes a car's fuse box has an extra place above the ignition fuse which is tied into the ignition fuse's socket. If so, put a spade crimp connector on the end of your pump's hot wire and insert the connector into the empty socket.

Put a circle crimp connector on the end of a wire, unscrew the electrolysis unit's wing nut from its positive terminal, slide the wire's end down over the terminal, and tighten the wing nut back down. Connect the other end of this wire to the same place you connected the hot wire from the pump. Apply another circle connector to the end of another wire, put it on the negative terminal (in the same way the wire was connected to the positive terminal), and connect the other end of this wire to the frame of the car.

Fill the tank to within a couple of inches of the top with water (purified water works best, but tap water will do). Place 3 tablespoons of old battery acid into the water (I personally have never used fresh, but my friend running it on his 4WD truck says he uses a lot less. (see the 'Improvements Section' ).

### **Step 3. Watch it work:**

Insert the tank into its mount in the engine compartment. Fit, but do not screw, the plug into the clean-cut such that you are able to see inside the tank. Make sure the tops of terminals are not touching any part of the car, have a friend turn on the ignition switch.

Watch inside the tank and you should see a bubbling action occurring at the electrodes. The negative electrode should have numerous bubbles forming and coming to the top from all over the surface area of the tin can lids. This is the hydrogen gas. The positive electrode will have bubbles forming all along its shaft. This is the oxygen gas. If the bubble action is not similar to that of an Alka-seltzer, add more acid (in small amounts) until it is. A normal car's electric system will have only about 12-14 amps of electricity going through it.

Therefore, assuming you have not stepped up the amperage in your cars system, you should never need much more than a total of 3 tablespoons of acid. If you are using old battery acid and find you need to add a lot, it is probably because someone watered down the acid while it was in the battery.

Be warned! Never use half acid and half water! This has caused one unit to explode! You may be tempted to think that if a little acid produces a little hydrogen, a lot of acid will produce a lot and therefore the car will be able to run on just hydrogen and oxygen. Again, be warned! This does not work. The principle of the electrolysis unit is to break apart water molecules by causing them to migrate to oppositely charged electrodes.

If you increase the amount of acid in the water, you end up allowing a good amount of current to flow from one electrode to the other. This results in an internal heating of the unit; expansion of the contents; and possible explosion of the unit. My friend was able to put 50 amps of power through his electrolysis unit instead of the 12-14 amps produced by a normal car battery. He uses purified water and new acid. He found the 50 amps allowed him to produce the same amount of hydrogen and oxygen gases while using less acid. He only used 2 drops of new acid per litre of purified water!

#### **Step 4. Finishing Assembly:**

Turn off the car and disconnect the wires from the top of the electrolysis tank. Apply a little petroleum jelly to the threads of the plug (it makes it easier to remove later) and insert the plug into the clean-cut. Reconnect the wires. The unit is ready to work for you!

#### **Improvements Section:**

There are some improvements to the design that I would like to mention here.

Using purified water instead of tap water increases the hydrogen and oxygen gas production reaction as there are fewer impurities in the water to get in the way of the electrolysis process.

As this unit uses electrolysis, the electrodes 'dissolve' as time goes on. The unit described above works well with the galvanised bolts, but after each 2 tanks of gas (average) the electrodes need to be replaced, though at an average cost of 69 cents each, this is not too expensive.

I believe that some air is being sucked through the open bleeder hole and gets pulled into the engine without becoming hydrogen-enriched. The more hydrogen that enters the system, the better the mileage will be so feeding air through the electrolyte should help. Obtain a length of 3/8 inch PVC pipe, 2 elbows, one end cap, 2 in-line connectors, and 1 valve. Drill a hole in the top of the plug that will allow a piece of 1 inch pipe to pass through while also leaving room that an in-line connector can be placed on the underside of the plug without interfering with its insertion into the clean-cut.

**USE NO CEMENT YET! THIS IS A TRIAL FITTING.** Cut a length of pipe such that when inserted in this hole, an in-line connector can be put on each end and be able to fit snugly together. Pass the pipe through the hole and put the in-line connectors on it. Insert a small section of pipe into the top connector, put the elbow on top of this. Insert another short piece into the elbow's free end and attach the valve to this. Put the tank in its mount under the hood and pivot the valve/elbow/pipe sticking out of the top such that the valve system does not interfere with the closing of the hood/wiring/etc. Glue the pieces together. Attach another section of pipe such that it will extend down into the tank and, when an elbow is placed on it, be just off the bottom of the tank. Insert this into the connector just under the inside of the plug. Cut another small length such that it can be inserted into the open end of the elbow; be capped; be pointed towards the middle of the tank; and fit into the bottom of the tank without running into the opposite side wall. Drill many 1/16 inch holes in a grid pattern all around the perimeter of this piece of pipe. Insert it into the elbow and cap it. Test, by assembling the entire tank unit, that this bubbler tube system does not interfere with the tank's assembly. Take the components of the bubbler tube system apart and glue them back together.

Install an in-line fuel filter on the output of the Hydro-boost unit. This is just to prevent any unwanted materials from entering the engine. You can get a clear one and mount it so that if any of the electrolyte from the unit comes out, it will catch in the filter and you can see it accumulating, drain it back, and lower your fluid levels to prevent this pull over from happening again.

Install your tee connector as close to the PVC valve as possible. This allows for better mixing and greater time factor for the hydrogen to react with the hydrocarbons in the PVC line. The end result is the reforming of the fuel into natural gas which produces a greater explosive force.

When you have a new, more explosive fuel, you should make a change to your ignition timing so it fires later. Normally a car's timing is adjusted so the spark fires just before the piston reaches top dead centre (TDC) in the cylinder. This allows the fuel time to ignite. When gasoline is ignited, it starts burning slowly. Then after the piston gets to the point where the power stroke starts, the main burn from the explosion begins and continues through the burn as the piston goes down. The fuel continues to burn in the exhaust system. With the Hydro-boost, the hydrogen-laden fuel reforms into a lower boiling hydrocarbon with a greater explosive speed and force. If the timing is the same as in a normal gasoline engine, the new fuel's explosive forces will fire before TDC and will not be properly harnessed. This will not aid mileage, but actually could reduce it as well as cause possible engine damage. The damage might be caused because the explosive force is pushing down when the piston cannot really move much (when at the TDC point). By retarding the timing, the forces can fire when the piston is ready to go down. You can set the timing for 3-5 degrees later. A tip for setting your timing: I have found (if you have no timing light) you can use a vacuum gauge. Just set the engine to the highest vacuum at idle.

I tried the air compressor system, using the car's existing air conditioning pump. The pump seized up 15 miles out. This

cost me a compressor. I am not sure if it was my fault for feeding direct voltage to the drive pulley coil or if it seized because it was not pumping Freon (what it was intended to pump). The inventor said his friend installed no special wiring, he just turned the air conditioner switch on. In the end, the air conditioner system cost me a compressor, belt, breakdown tow, and aggravation. I have since learned there are two types of compressors One will work one will not. Instead I used a 12 volt inflator blower, the type for beach toys. It was effective in moving the gases but did not create a great vacuum which seems to help to give the extraordinary mileage.

Instead of using battery acid you can use baking soda or hydrogen peroxide to make an electrolyte for your hydrogen supply. Battery acid is not always readily available. Some may worry about acidic transfer to the engine, so it may be better to run both baking soda and acid alternately. The baking soda is a base that will neutralise the acid if any is transferred.

You can just make a simple sight gauge as I did to check fluid levels. Just use two 1/4 inch N.P.T. elbow to 3/8 tube. Fit one on top, one on bottom, and use clear vinyl tubing in between. Position this gauge so you can just pop the hood and look at the tube to determine your fluid level. You may even want to use a T-connector at the top of this gauge (instead of an elbow), put a removable cap on it, and use this as a way to replenish the fluid levels.

To know that the unit is working (and to what extent), you should install an amp meter (just the standard style) in line with your electrode. This will enable you to add to the acid content until you get the 10-12 amps. If you check it out occasionally, you will see when your amperage is down. When it's down to 4-5 amps, you know to check water level; acid content; or condition of your rods and plates (for cleaning or replacing as set out in first section of the text).

I have not tried other metals for the rods but tried galvanised metal electric box covers for the plates because my tomato can lids disintegrated. I used the octagon type covers and cut them in half Just trim the end to fit the container. I did drill the holes as described in the instructions. Because the water/acid does appear to 'boil' (produce gas) at the edges of the holes. You could get half inch rod in a variety of metals and just cut a half inch thread on the ends to mount or hold plates. Also, you could get a one inch compression fitting, drill it out for the rod to go through, and just use stainless steel gear clamps to attach the wire and plates. Cut the letter H on your plates where you want your rod to go through, bend the tabs the same way, push your rod through, and clamp with a gear clamp over the tabs to hold the rod in place to give an electrical circuit.

I recommend putting a fuse in the circuit. Use a 25 amp fuse. I have seen the metal deposits form spikes in the plates and it could be possible to short out. Fusing a Circuit is always a good idea in whatever you are doing. Safety first.

I recommend using a good oil additive that bonds to the metal for extra protection. I recommend MT-10 for oil and FT 10 in your fuel for upper cylinder lubrication. You will want a little extra lubrication in your engine because you are getting a little more water in your combustion with this system.

Multiple electrodes plates may help. Instead of 2 electrodes, use 4 or 5 and insulate between them a the 12 volts is probably better spaced out 2-3 volts per area between the plates. As for as gas goes, I would like to see enough produced triple the miles per gallon on a regular basis.

[End of excerpt]

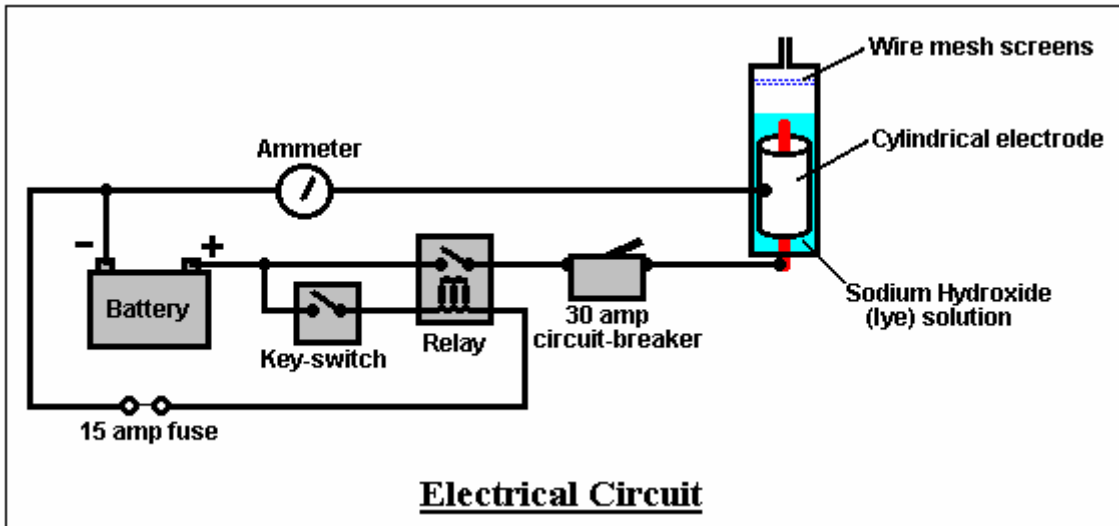
**Comments:** The increase in mileage claimed is interesting as is the use of an air pump. The improvement in consumption may well be assisted by creating a leaner mix and introducing water vapour, as well as the hydroxy gas generated. The electrolyte should be Sodium Hydroxide or Potassium Hydroxide and not acid.

**Another design:** "HoTsAbI" - a member of the Yahoo 'egaspower' discussion Group has developed a very neat electrolysis unit which has raised his average mpg from 18 to 27 (50% increase) on his 1992 5-litre Chevy Caprice. As you can see, he has made a very neat and professional installation which works very well:



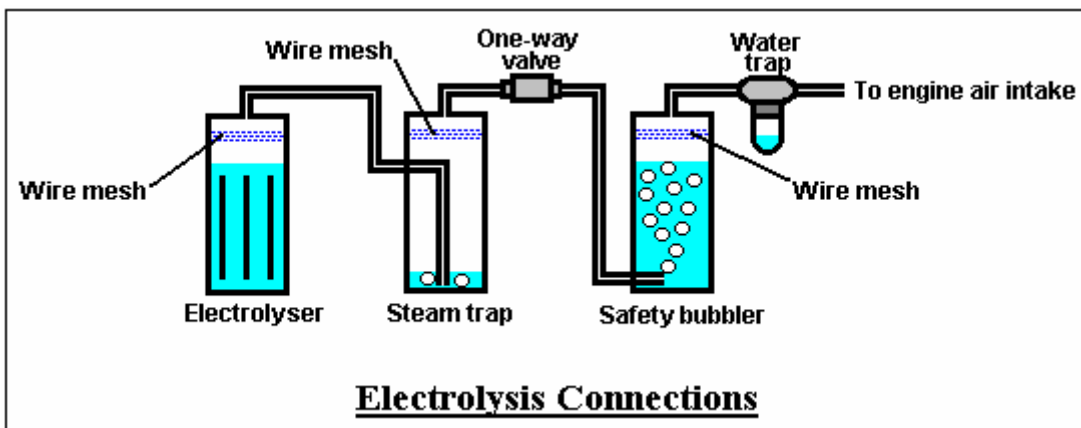


The unit draws only 15 amps which is easily handled by the existing alternator. The construction uses ABS plastic with Sodium Hydroxide ("Red Devil" lye, 1 teaspoon to 8 litres of distilled water) and the gas-mix is fed directly into the air intake filter of the car engine. The electrodes are stainless steel with the negative electrode forming a cylinder around the positive electrode:



The circuit is wired so that it is only powered up when the car ignition switch is closed. A relay feeds power to the electrolyser which is three inches (75 mm) in diameter and about 10 inches (250 mm) tall. The electrolyser circuit is protected by a 30-amp circuit breaker. The electrolyser has several stainless steel wire mesh screens above the water surface.

The output of the electrolyser is fed to a steam trap, fitted with several stainless steel wire mesh screens, and then on via a one-way valve into a safety bubbler:



The bubbler also has stainless steel wire mesh screens which the gas has to pass through before it exits the bubbler. The gas is then passed through a compressor-style water trap to remove any remaining moisture, and is injected into the air intake of the vehicle. Although not shown in the diagram, the containers are protected by pop-out fittings which provide extra protection in the extremely unlikely event of any of the small volumes of gas being ignited by any means whatsoever.

The ammeter is used to indicate when water should be added to the electrolyser, which is typically, after about 80 hours of driving and is done through a plastic screw cap on the top of the electrolyser cap (shown clearly in the first photograph). This unit is now available commercially. If you want to buy one, then send an e-mail with "e-cell" in the title, to [hotsabi@gmail.com](mailto:hotsabi@gmail.com) asking for availability and details.

## ***Pulsed Electrolysis:***

**Stanley Meyer.**



On 17th December 1995, the Channel 4 television series 'Equinox' ran a programme which included an interview with Stanley Meyer of Ohio, USA. I watched Stan demonstrate a new method of separating water into its components of hydrogen and oxygen. His method is some 17 times more efficient than conventional electrolysis. With conventional electrolysis, the temperature of the water (plus additives to help the process) rises substantially during the process. With Stan's method, the water temperature does not rise at all and no additives are needed. This strongly suggests that his method utilises zero-point energy to provide the extra power needed to break down the water. Zero-point energy shows a temperature *drop* as the current increases.

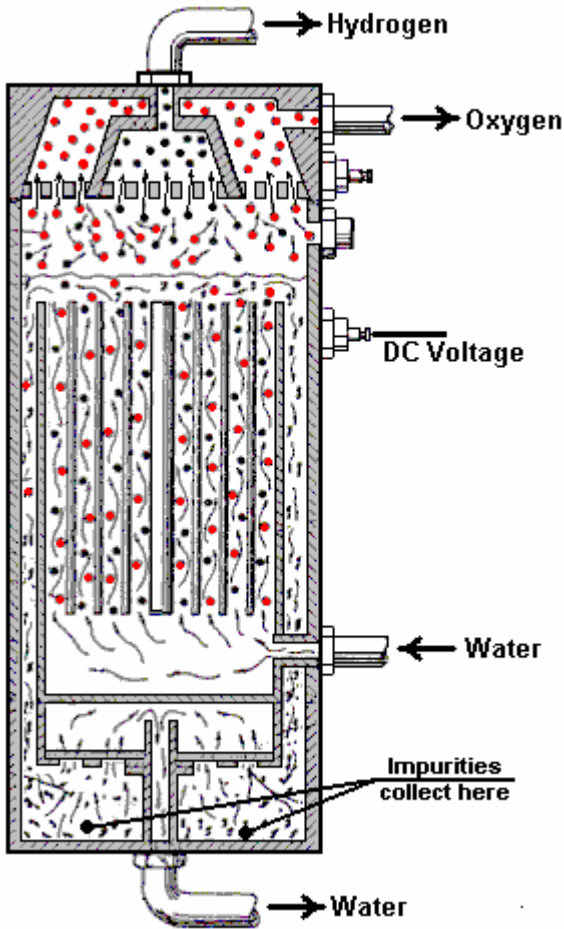
Stan received several patents covering his process, including US 4,798,661; 4,936,961; 4,826,581; 4,798,661 and 4,613,304. His first patent was very difficult to obtain as the US Patent Office said it was impossible to do and demanded to see a working model. Stan gave them a demonstration but even then, they took a further three years of stalling before they issued the patent. Stan is no longer alive and we do not have exact step by step building plans. So, what do we know about his system?:

1. It has been demonstrated and the demonstration can be reliably repeated as often as wished.
2. Tap water or distilled water is used with no electrolyte and is consumed rapidly.
3. Any voltage from 5V upwards can be used but the higher voltages are more efficient.
4. Low current is used, averaging only 100mA at the higher voltages.
5. Electrodes may be flat, curved or cylindrical and stainless steel is a suitable material.
6. Gas production rate increases as the plate separation decreases: a 1.5mm gap is recommended.
7. One or more external inductors are used and resonance with the cell capacitance is sought.
8. The electrical input is a high-frequency DC pulse generator giving sets of short pulses with a gap inbetween them.
9. The pulses build a rising DC potential across the electrodes until the water breaks down and a high current flows. The supply detects this and removes the pulse train for a few cycles, which allows the water to recover.
10. Increasing the voltage, increases the gas production rate.
11. Stan claimed to have run his VW car on hydrogen for four years, using six cells containing cylindrical electrodes.
12. Stan stated that photon stimulation of the reaction space by optical fibre piped laser light, increases the gas production rate, but this stimulation is not essential.
13. The pulses applied to the cell are all of the same polarity.
14. The objective is to produce a resonance in the cell, so the input frequency is adjusted to achieve this. The voltage is then increased to raise the gas production rate.
15. One patent states that varying the pulse shape and/or amplitude, varies the gas production rate.
16. The step-up transformer used is wound on a conventional toroidal core formed of a compressed ferromagnetic powdered material which will not become permanently magnetised, such as the trademarked "Ferramic 06# 'Permag' powder" as described in the Siemens Ferrites Catalogue, CG-2000-002-121, (Cleveland, Ohio) No. F626-1205". The core is 1.50 inch in diameter and 0.25 inch thick. The primary winding is 200 turns of 24 AWG copper wire and the secondary, 600 turns of 36 AWG wire. Stan had several prototypes and elsewhere he mentions a primary of 100 turns of 24 AWG wire and a step-up ratio of more than five times, so the secondary probably remained at 600 turns.
17. The primary coil of the torroid is given a 50% duty cycle pulse
18. The input generates a voltage across the electrodes of 1000V or more. The pulse train is then switched off. The voltage across the electrodes drops to the amount of charge that the water molecules have taken on. The pulse train is then applied again. This produces an ever increasing electrostatic charge between the electrodes.
19. In this process, the electrical resonance may be reached at all levels of voltage. The overall circuit is characterised as a "resonant charging choke" circuit, which is an inductor in series with a capacitor. Such a resonant charging choke is on each side of the capacitor. In the circuit, the diode acts as a switch which allows the magnetic field produced in the inductor, to collapse, thereby doubling the pulse frequency and preventing the capacitor from discharging. In this

manner, a continuous voltage is produced across the capacitor plates in the water bath, and the capacitor does not discharge. The water molecules are thus subjected to a continuously charged field, until the covalent bond breaks down, creating the gas production.

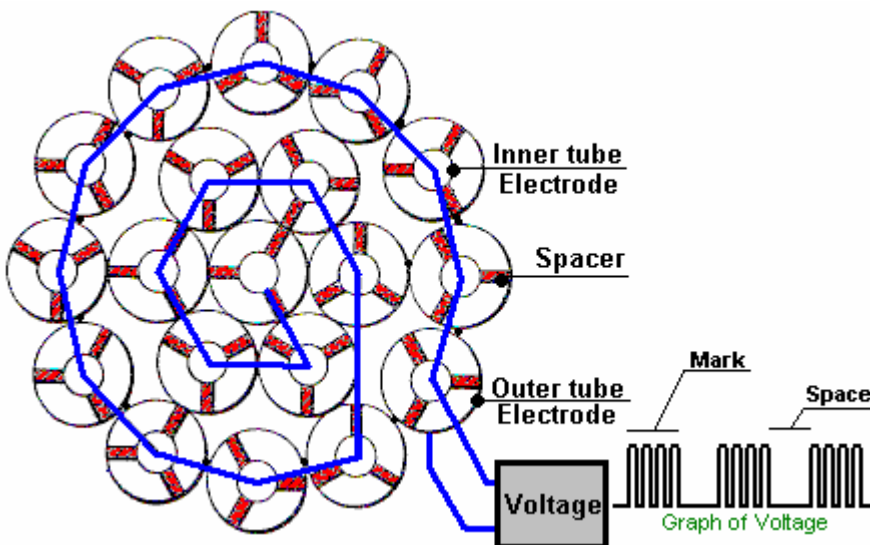
20. Stan's electrode dimensions were 0.75" diameter for the outer pipe and 0.5" diameter for the inner electrode pipe. This gave a separation of 0.625" (1.588 mm) between the electrodes.
21. Resonance in the circuit is achieved by adjusting the pulse rate until the current flow is minimised and the voltage developed across the electrodes is maximised.
22. The resonant frequency of this circuit is determined by the water dielectric, plate size, plate configuration, plate separation, circuit inductors and the like.
23. Control of gas production is achieved by varying the time between the trains of pulses, the pulse amplitude and the capacitor plate size and configuration (with the corresponding value adjustments to the other circuit components).
24. One patent states that a variable resistor, between the cell and the negative line, is used to reduce the working current to a negligible level. This presumably replaces the variable coil (rheostat) shown on some of his diagrams. He then states that he also uses a home-built capacitor in series with the variable resistor (he is somewhat vague on the details).
25. The gas generation rate is said to be controlled by both the applied voltage and the mark-space ratio of the pulse interrupter circuit.
26. Current leakage can be reduced in a multi-plate cell by having a separate power supply for each pair of plates.
27. The smaller the gap between the plates, the greater the gas production, *but* the greater the current leakage, so the plate spacing choice is a compromise.
28. One functional unit was operated with a voltage range from 0V to 45V.
29. To obtain optimum operation, Stan used a gas flow-meter and an ammeter to set the best operating conditions.
30. The circuit can be tuned to any plate arrangement by adjusting the frequency of the pulses or by adjusting the mark-space ratio between the pulse bursts. The suggestion is to tune initially with the frequency of the DC pulses, and then reduce the leakage current by adjusting the mark-space ratio control.
31. In one instance, a 40:1 step-up transformer was used to increase the voltage applied to the cell plates to some 200V to increase the gas flow rate.
32. Unless using distilled water, the water will contain some impurities. When the water is split into hydrogen and oxygen, the impurities are left behind and they collect as what Stan describes as 'sludge' at the bottom of the cell. Some provision for removing this residue should be provided as part of the cell construction.

One of Stan's cells designs is shown here:



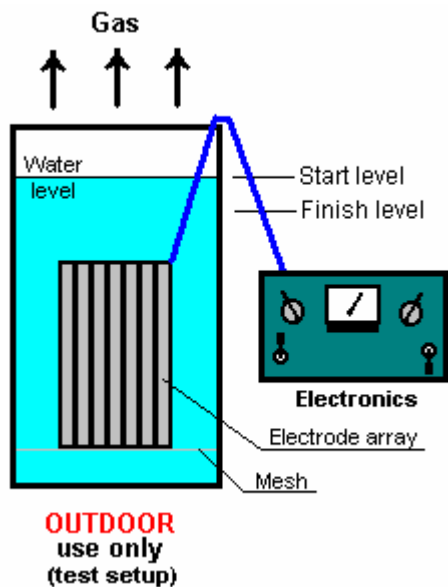
You will note that he uses a DC voltage on the wall of the cell to move the dissociated hydrogen atoms outwards and the oxygen atoms inwards, to produce separate gas exits from the cell.

One of his common (pipe) plate arrangements is shown here:



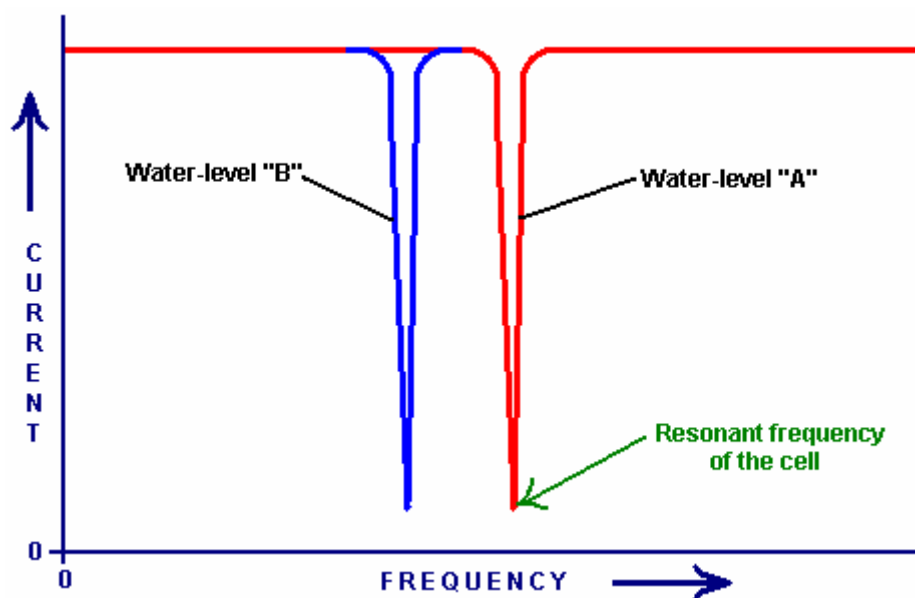
I do not recommend that you experiment with hydrogen. However, if you decide to, then please be aware of the danger. If any of the hydrogen you produce escapes, it will spill upwards and collect on the ceiling of any room you are in and it can stay there for days. It is highly flammable on its own, but it will mix with the air in the room to form an explosive mixture which can be set off by any spark, cigarette or naked flame.

You would be much better off to run any experiment outdoors in an uncovered area. That way, any escaping hydrogen rises and is dispersed by the wind. Test apparatus can be of very simple construction. You do not need to capture the hydrogen/oxygen mix. You do not need a gas-flow meter. Just place the electrode array in to a regularly shaped container which has two water levels marked on it:



Fill the container to the upper mark, start the experiment and measure the length of time it takes for the water level to fall to the lower mark. It is much easier to measure the loss of water than to capture the gas and measure its volume and pressure.

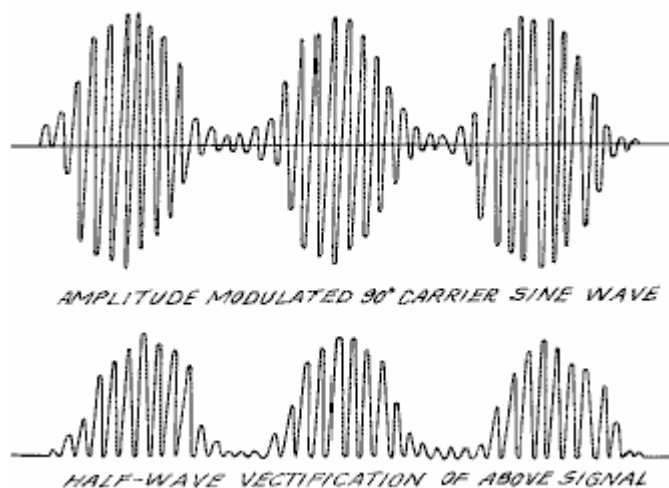
It should be understood that while Stan's system of splitting water is the most efficient around, it is not easy to achieve and even more difficult to maintain. The resonance of the cell is very sharp indeed, and can generally only be found by careful monitoring of the current while adjusting the pulse frequency very, very slowly. The diagram shown here indicates how narrow the resonance 'notch' is:



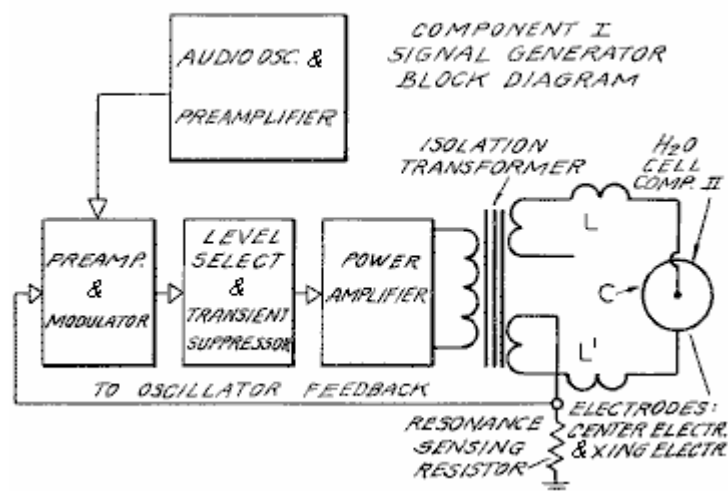
Even at frequencies very close to the resonant frequency, there will be no indication whatsoever that the frequency has almost been reached. When the correct tuning point has been found (at water-level "A"), the water-splitting accelerates to a high level, and unless the water supply is being pumped through the cell as Stan shows in his patent drawings, then the water-level starts to drop. Unfortunately, as the water level drops, say to water-level "B", the resonant frequency of the cell alters and the pulse train is then at the wrong frequency and the process stops to perform correctly. To maintain maximum low-current gas production, either the cell conditions have to be held constant to a high degree of accuracy, or sophisticated electronic control is needed to keep re-adjusting the pulse frequency to the exact resonant frequency, faster than the cell characteristics can change.

For these reasons, none of the experimenters, which I know of, who have achieved this type of water-splitting, have managed to produce a fully operational practical cell. It may also be the reason why Stan moved away from this type of cell in favour of direct water injection into his car engine, creating the combustion conditions inside each cylinder just before ignition. The injection system has the enormous advantage of not needing to handle gasses of any type but just move and manipulate ordinary water. Stan died suddenly just after perfecting and demonstrating his water injection system and before it went into production - an amazingly convenient occurrence for the oil industries.

**Henry Puharich.** Henry also used a pulsed signal to split water molecules in an efficient manner. His technique is rather different in that he starts with a modulated audio sine-wave signal and uses half-wave rectification to cut off the negative voltage components. The result is a pulsed DC signal which has a whole range of different amplitudes as shown here:

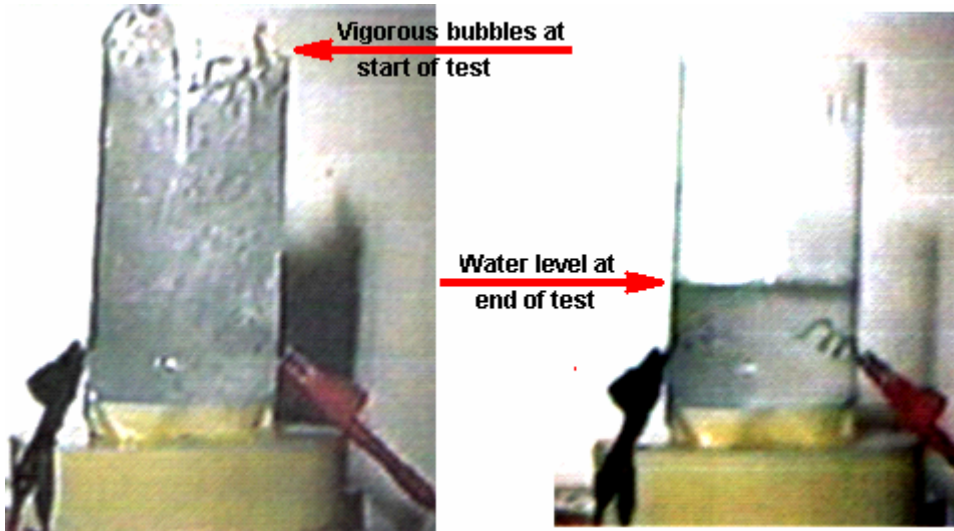


This waveform is generated using the arrangement shown here:



The details of his process can be found in his patent, a copy of which forms part of this set of documents.

**Paulo Mateiro.** It is reported that water has been efficiently split by Paulo Mateiro, using the most simple electrodes possible, with only 4.8 Volts from a 555 timer circuit. Different frequencies from 200Hz to 1,100Hz have been used and for the cell in the test, the optimum was 923Hz. The current was 300mA and the hydrogen production was so great that the bubbles were almost tossing the water out of the top of the container as shown here:

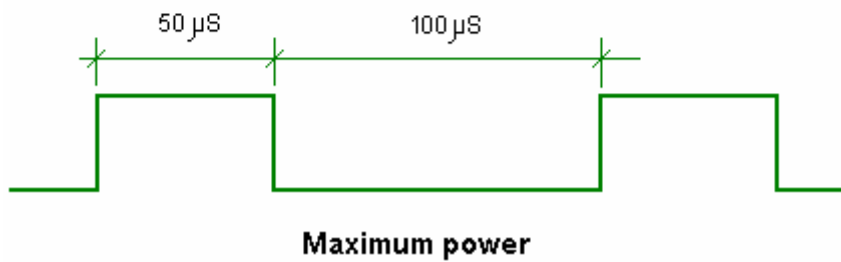
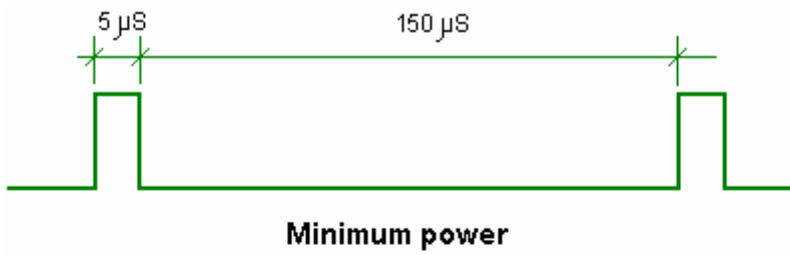


This is said to split one litre of water per minute in a single cell with just bare wires for the electrodes and a straight square wave between the electrodes. He used 10% sulphuric acid solution (probably unnecessary). Anode and cathode were 35 mm (1.4 inch) long, silver-coated copper wire. Paulo ran his internal combustion lawnmower directly from water using this method:



**Kiyoshi Inoue (Tokyo).** Kiyoshi has been granted US Patent 4,184,931 for an efficient pulsed electrolysis system. His recommendation is for a pulse waveform which has an "on" period of from 5 to 50 microseconds (500 microseconds at a push) and an "off" time of 2 to 30 times the "on" time. His circuit provides independent adjustment of both the "on" and "off" times (a simple circuit to do this is in the electronics tutorial section of this set of documents). His electrolysis voltage will therefore adjust anywhere between the two waveforms shown here:

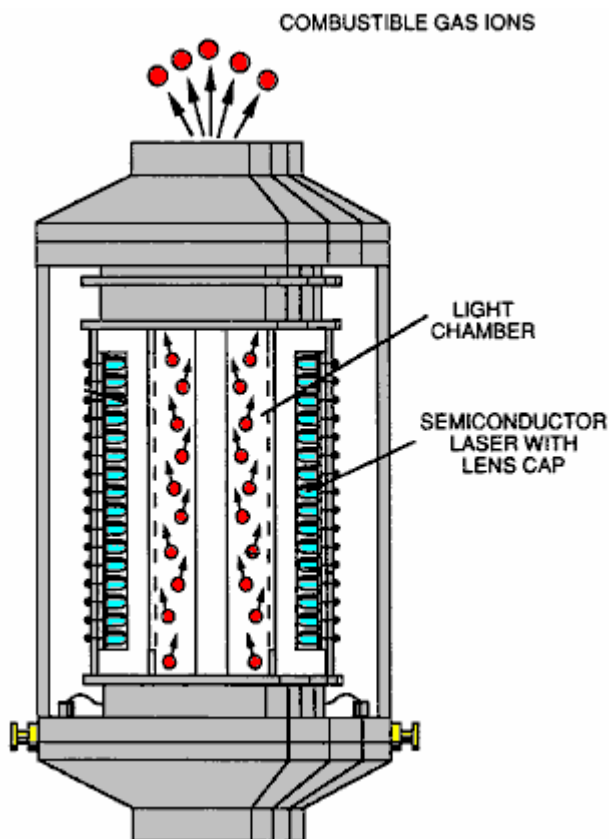




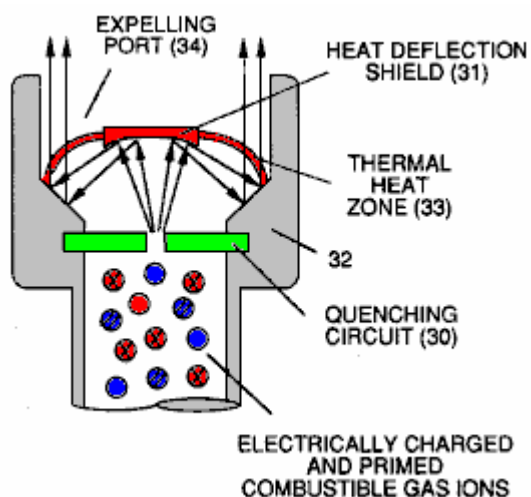
**Fuel Injection:**

**Stanley Meyer**

The most advanced way to power a vehicle is using injection straight into the cylinders. Stanley Meyer did this and put a vehicle on the road. Stan's system is very advanced. He starts by pumping energy into the water molecules by passing them through transparent tubes using arrays of solid state UV lasers to radiate energy into them:

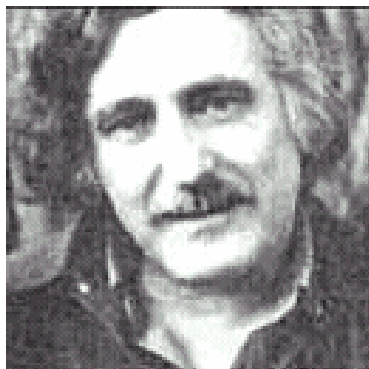


He then adds more energy to the water molecules by pumping both heat and magnetic energy into them with a special assembly heated by the previous power strokes in the cylinder:

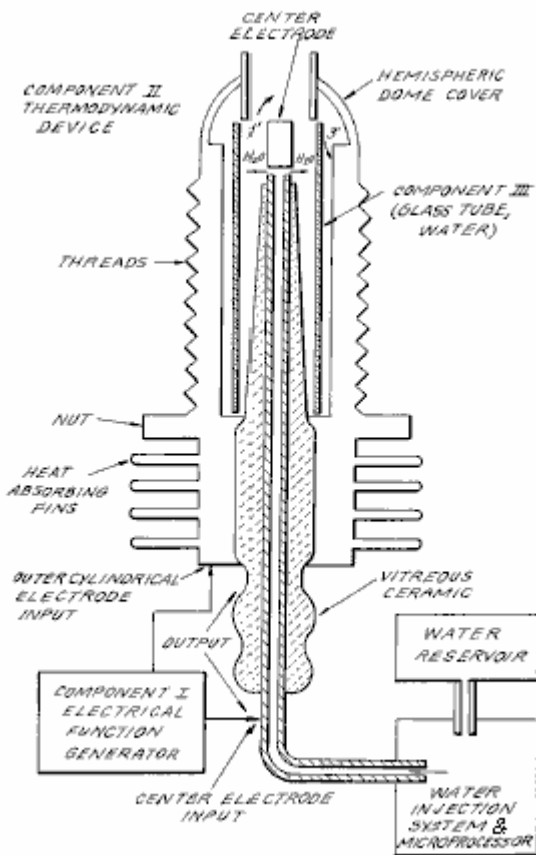


At this point, the mixture is ready for injection into the cylinder for compression and ignition. Stan's system is very effective and can power a vehicle engine directly from water as the only fuel. The full details of his patent form part of this set of documents accompanied by a very extensive discussion of how Stan saw the energising process and some of his other patents.

### Henry Puharich

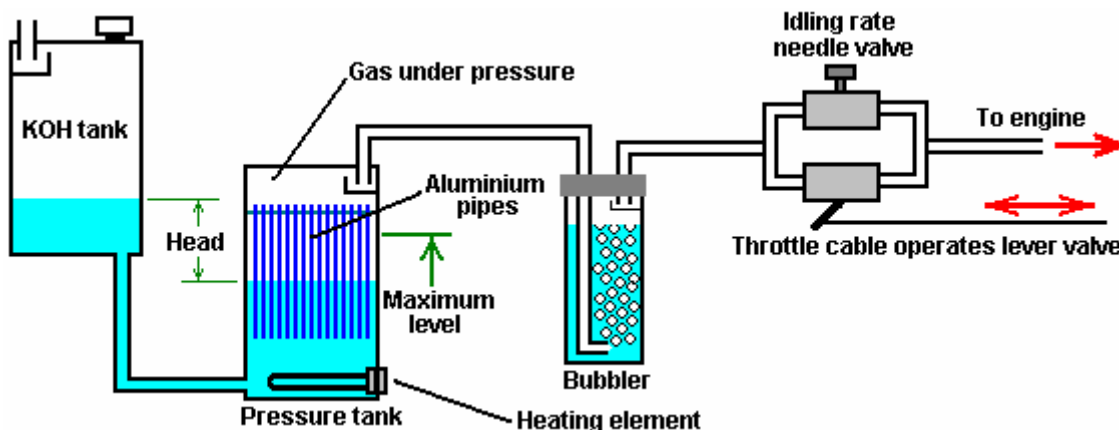


Henry gives a very detailed description of how he sees water bonding, energy levels and splitting process in his 115% efficient water-splitting patent, a copy of which forms part of this set of documents. He too, opts for injection of hydroxy gas directly into the cylinder as shown here:



**Rothman Technologies.** Since 2003 Rothman Technologies of Canada have been running a 12HP petrol motor on hydrogen produced by a chemical process. This is a cheap process in which metal is consumed and so, although of great interest, this is not a 'free-energy' engine. A recent patent application by William Brinkley proposes a system where aluminium pipes are consumed by a 25% solution of Potassium Hydroxide heated to 180 degrees Fahrenheit. William remarks on the non-polluting nature of the system, but this is not really so in that a very large amount of energy has to be put into producing the aluminium metal in the smelting and refining process, and the pollution is just moved from the end user to the industrial plant. Francis Cornish of the UK has a system where electrolysis of water is combined with a chemical process consuming aluminium wire. The system works well, but I have reservations about using consumables which tie you to industrial manufacturing, also concerns about the reliability of mechanical feed systems when they are being used by non-technical people (most car drivers). There is also the issue of removing and recycling the chemical residue generated by the process.

I personally am not keen on chemical processes and I do NOT recommend that you construct anything based on the following description. However, it might be possible to adapt the Brinkley system so that it operates with no moving parts:

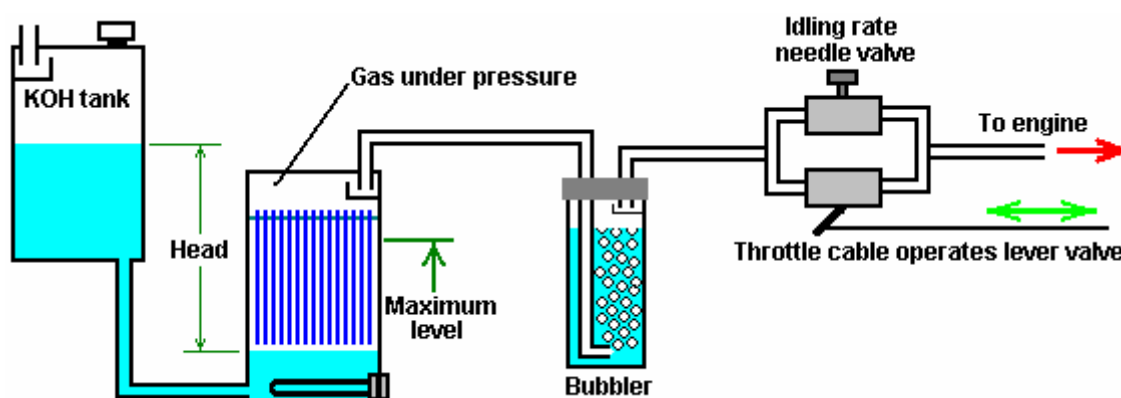


Here, there is a header tank containing a 25% mixture of Potassium Hydroxide (KOH) in water. This tank is positioned higher than the pressure tank where the hydrogen gas is generated and the venting pipe is protected by a baffle. The

venting pipe should provide an outlet to the air outside the vehicle or building which contains the system.

Initially, the KOH solution in the pressure tank is heated by the heating element, but when the process gets started, it generates heat to maintain the chemical reaction. The gas generation then builds up pressure in the strongly-built pressure tank. The raised pressure pushes some of the KOH solution back into the header tank, against gravity. This reduces the area of aluminium exposed to the KOH solution and reduces the rate of gas production. This effectively creates an automated gas production rate control which has no moving parts.

If the rate of gas taken by the engine increases, that lowers the pressure in the pressure tank, allowing more KOH solution to run into the pressure tank, increasing the rate of gas production. When the engine is stopped completely, then the KOH solution gets pushed into the header tank until all gas production stops, as shown here:



This looks as if the pressure tank is under considerable pressure, but that is not so, as the header tank is open to atmospheric pressure. I have concerns about controlling purely chemical processes rapidly enough for practical use. The above system would be more suited to a fixed engine, such as an electrical generator, where the gas requirement does not fluctuate greatly. The KOH tank shown above should be large enough to contain all of the KOH solution in case the gas production just does not stop when it should. The vent from the header tank should be capable of venting excess hydrogen with no possibility of it ponding on a ceiling and forming an explosive mixture with air.

Only 5 pounds per square inch of pressure is needed for electrolyser systems to feed a car engine satisfactorily, so a relatively low pressure is quite satisfactory, provided that the piping is of reasonable internal diameter. It should be remembered that the car engine will be applying a slight vacuum through the bubbler. As with all of these systems, it is vital that at least one bubbler is used between the gas production and the engine, to guard against flashback from the engine ignition if faulty ignition should occur. All bubblers should have a tightly fitting pop-off cap which can ease the effect of an explosion, and they should contain only a small amount of gas. The method of connection to the engine and the necessary timing adjustments are shown and explained in the 'D9.pdf' document which forms part of this set.

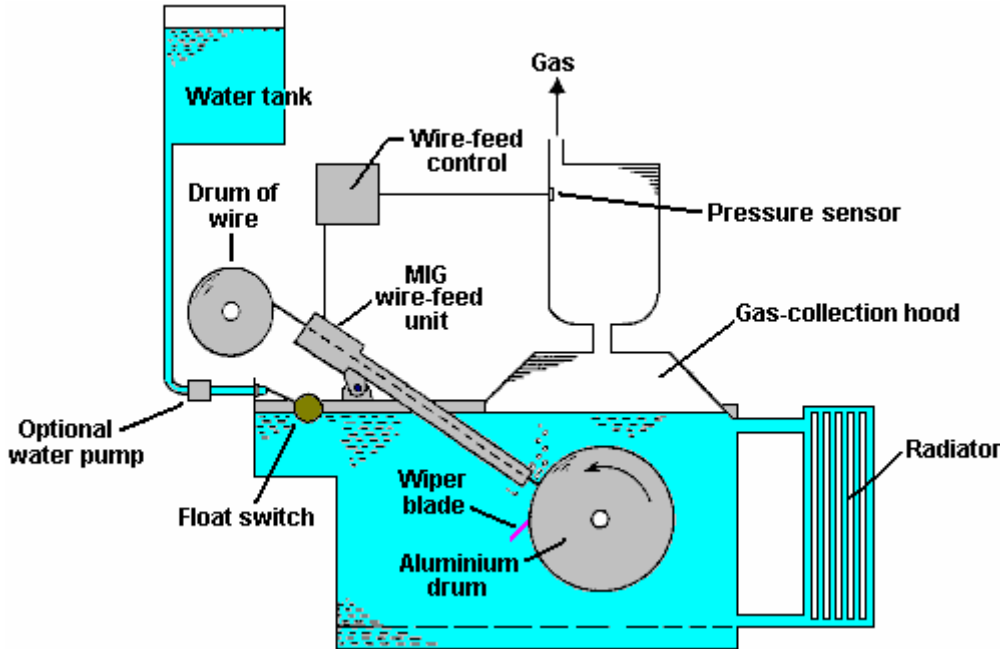
**Francois Cornish.** The method of using aluminium for a fuel in an on-demand hydrogen system for vehicle propulsion has been presented in detail by several people. One of the best known is the 1987 US Patent 4,702,894 by Francois Cornish, where he uses a feed mechanism for aluminium wire to maintain an underwater electrical arc which raises the water temperature high enough to make the aluminium react with the water. The rotating drum is made of aluminium but as it has a much larger thermal capacity than the aluminium wire being fed towards it, the drum temperature is much lower than that of the wire. As a result of this, the wire reaches the temperature required to make the aluminium react with the water. The chemical reaction releases hydrogen and converts the aluminium wire to aluminium oxide powder, which settles on the bottom of the tank, passing through a grid just above the bottom of the tank.

The bubbles of hydrogen gas released by the reaction tend to stick to the rotating aluminium drum, so a wiper blade is provided to sweep the bubbles off the drum. The bubbles then rise to the surface of the water and are directed into the gas collection chamber by a funnel located above the arc. If the engine demand drops and the pressure in the gas collection tank rises, a sensor located in the tank causes the wire-feed control electronics to stop the wire feed which cuts off the gas production.

At first glance, a system like this appears to have limited appeal. It uses aluminium wire which requires manufacturing by a process which uses substantial amounts of energy and while a vehicle using hydrogen produced by this method will generate very little pollution, the pollution occurs at the point of manufacture. Also, the device uses a mechanical wire feed and any device of that nature will need regular maintenance and may not be 100% reliable. In addition, the

aluminium oxide powder will have to be cleaned out of the generating tank on a routine basis.

But, having said all that, the system has some very significant advantages. It does not use any fossil fuel (directly). It can be readily installed in a vehicle and the consumption of aluminium wire is surprisingly low. Figures quoted indicate that typical consumption is of the order of 20 litres of water, plus one kilogram of aluminium used to cover 600 kilometers distance (1 pound per 170 miles). This is probably a good deal cheaper than using fossil fuel to drive the vehicle. The system is set up like this:



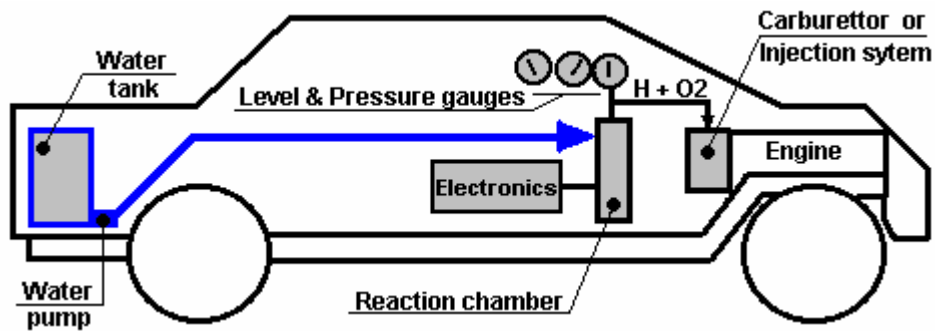
Another system of interest is the self-powered electrolysis system of the 1992 US Patent 5,089,107 granted to Francisco Pacheco where sacrificial anode plates of magnesium and aluminium are placed in seawater opposite a stainless steel cathode. Electrical power is generated and hydrogen produced on demand. There is also surplus electrical power available to run a standard electrolyser if so desired.

**Car Applications.** It appears that the most popular application based on splitting water is to run a car, either as a supplement to petrol or as a full replacement for it. There are some practical issues involved in using a hydrogen/oxygen mix to run a standard car engine. Firstly, the timing is likely to have to be adjusted to a different setting. Secondly, hydrogen has a high energy content and is likely to cause the engine to run hotter, Thirdly, the pistons and exhaust system are liable to rust unless coated or replaced with stainless steel components. There are various sets of plans for car conversions. These plans assume a reasonable level of mechanical skill on the part of any person or group who undertakes this sort of work. The plans shown here are published on the website:

<http://www.spiritofmaat.com/archive/feb2/carplans.htm> and are intended for free use by anyone who wants to utilise them. They stress that should you decide to undertake any work of this nature, both they and I are in no way responsible for any loss or damage which might result. They also stress that they themselves have not done a conversion of this type, and while they see no reason why these plans should not result in a perfectly workable vehicle, they themselves cannot guarantee that the plans do work. Most of the experienced members of the 'waterpower' and 'hydroxy' Groups do not believe that this system would produce sufficient hydrogen to run an engine, but that the mechanical details shown can be useful to constructors. The full manual is included in the documents under the name "HydroStar" and the full manual for an essentially updated version of the design is included under the name "HydroGen".

It is recommended that should experimental work be undertaken on a car, then the car chosen should be of little value and that all existing parts be kept so that the vehicle can be restored to its present fossil-oil burning status should you choose to do so. It is also suggested that you use a car which is not important to your present transport needs.

It is claimed that the modified car will travel 50 to 300 miles per gallon of water depending on how well it is tuned. The system is set up like this:



Here, the car has an extra tank installed to contain a reserve of water. This is used to maintain the water level in the reaction chamber which contains the electrode plates. The electrodes are driven by the electronics which applies a pulsed waveform to them in the 0.5 to 5.0 Amp range. The electronics box is powered directly from the existing car battery. The Hydrogen/Oxygen mix which is the output from the reaction chamber is fed directly into the existing carburettor or fuel-injection system.

The start-up procedure is to power up the electronics and wait for the gas pressure to reach the 30 - 60 psi range. Then the car ignition is operated as normal to start the engine. The accelerator pedal is wired into the electronics to give more power to the electrode plates the further the pedal is pressed. This increases the gas production rate as the throttle is operated.

### Components:

- Plastic water tank with pump and level sensor.
- Control circuit, wiring, connectors, and epoxy resin.
- Reaction chamber with electrodes and fittings.
- 3/8" stainless steel flex-tubing, fittings and clamps.
- Vapour-pressure fitting kit for the carburettor or fuel-injection system.
- Pressure, CHT (or EGT), & level gauges.
- Stainless steel (engine) valves.
- Copper mesh junction.
- Ceramic surface treatment for cylinders & pistons.
- Stainless steel or ceramic treated exhaust assembly.

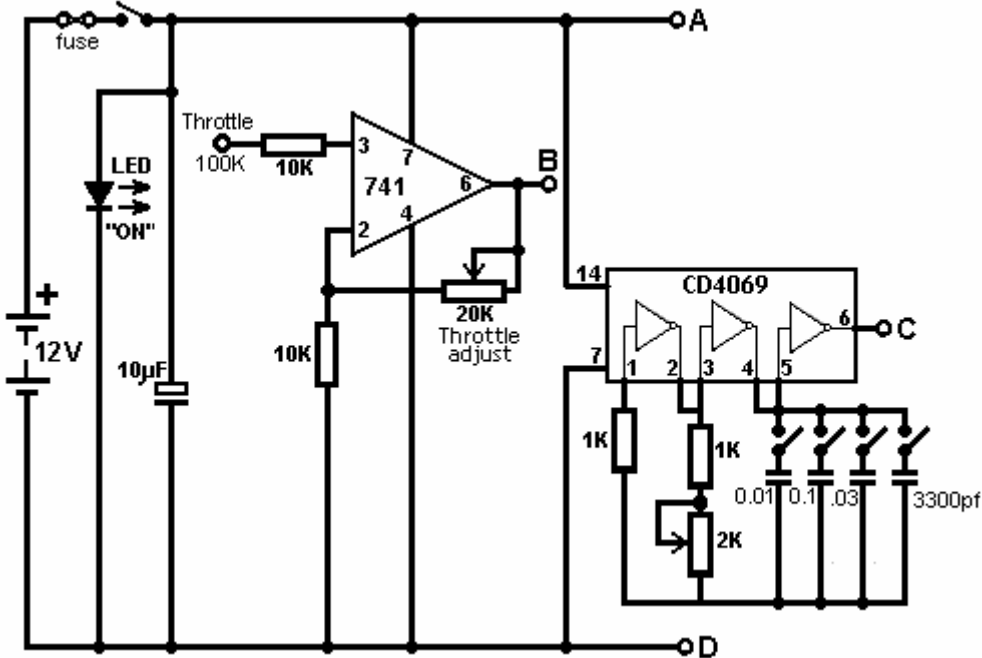
### Suggested Construction Sequence:

- Build and test the electronics circuit to verify the correct pulse output.
- Build the reaction chamber and test it with the controller (i.e. pressure out).
- Install the tank, controller, chamber, and pressure fittings.
- Run engine and adjust the control circuit as necessary for best performance.
- Install the stainless steel valves and get the pistons/cylinders coated with ceramic.
- Coat the exhaust system with ceramic without the catalytic converter (or let it rust out and then replace it with stainless steel pipe sections).

These plans do not show it, but may I most strongly recommend that you place a, say 60 psi, pressure-operated switch on the reaction chamber and wire it so that if the pressure exceeds sixty pounds per square inch, then the electronics is powered down to stop further gas production and prevent further increase of pressure in the chamber. This covers the situation where the driver switches the electronics on and is distracted before he operates the ignition to start the engine. Please also note that it is absolutely vital to have a flash-back preventer device between the engine and the reaction chamber, so that should there be any form of malfunction, there will not be an explosion in the reaction chamber.

## Electronic Control Circuit:

The diagrams show a simple circuit to control and drive this mini-system. You are going to make a 'square-pulse' signal that 'plays' the electrodes like a tuning fork; which you can watch on an oscilloscope. The premise given by the literature is: the faster you want to go down the road, the 'fatter' you make the pulses going into the reaction chamber. Duty cycle will vary with the throttle from a 10% mark/space ratio (10% on and 90% off) with the pedal up, to a 90% mark/space ratio with the pedal fully down.



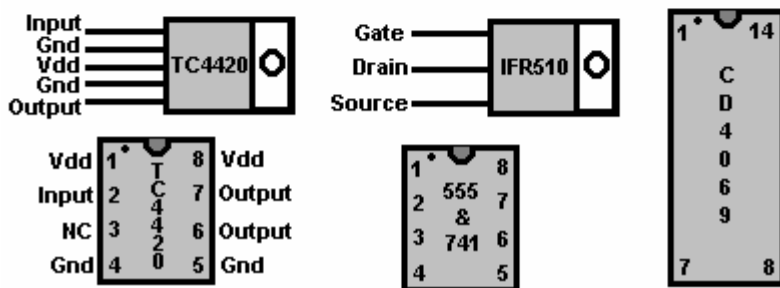
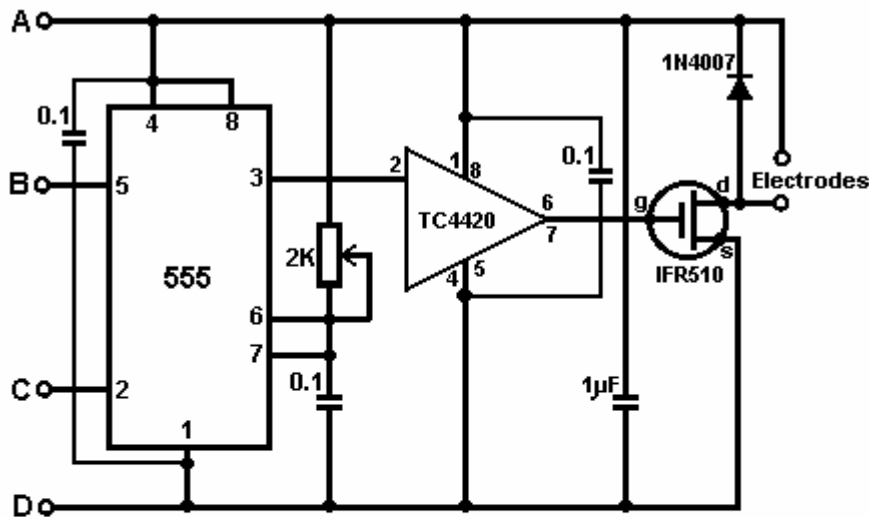
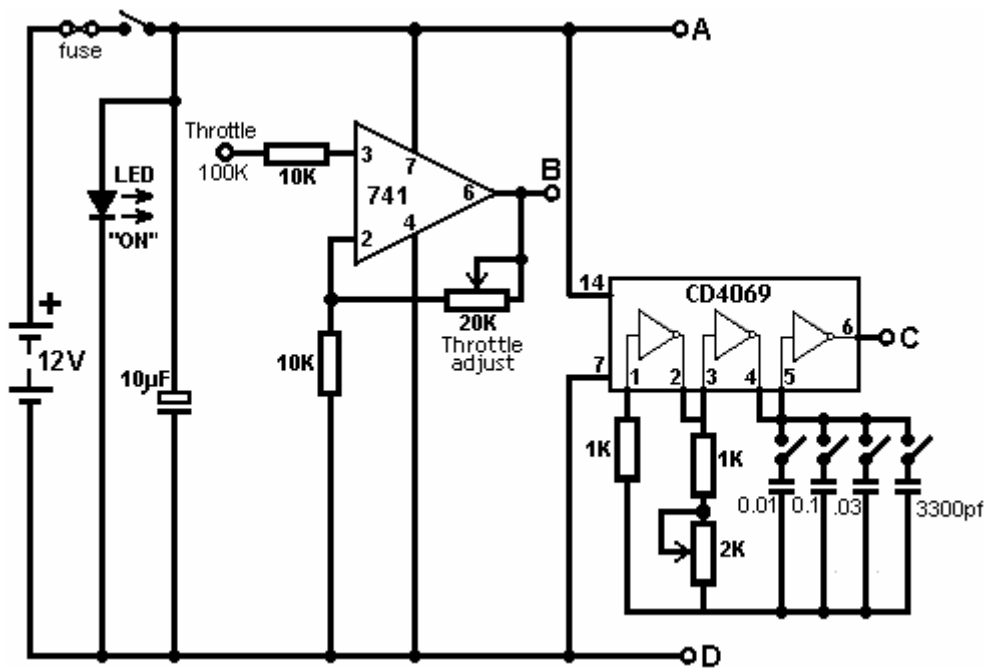
There are many ways to generate pulses. This circuit uses an NE555 integrated circuit. The output switching transistor must be rated at 5 Amps, 12V for pulsed operation. Be sure to use a circuit board with a built-in ground plane, and leave room to mount 2 or 3 of the gauges. Mounting the reaction chamber in the engine compartment will require running a stub to your pressure gauge where you can watch it. You will want to get your chamber level sensor verified before you epoxy the cap on.

If there is a throttle-position sensor on the car, you should be able to take the signal from the sensor itself OR from the computer connector. This signal is then fed into the circuit as the primary control (i.e. throttle level = pulse width = gas rate).

If you don't have such a signal available, you will have to rig a rotary variable resistor to the throttle linkage (i.e. coupled to something at the accelerator pedal or throttle cable running to the carburettor or Fuel-injection system). If you make the attachment at the carburettor/fuel-injector, be sure to use a variable resistor which can handle the temperature to which it will be subjected. If it is subject to high temperatures, get one rated for long life and mechanical wear; mount it securely to something sturdy and stationary that will not fall apart when you step on the accelerator pedal. The throttle operation needs to generate a voltage swing of some 4 Volts to give a 10% to 90% mark/space ratio swing on the oscillator. The oscillator frequency should be matched to the resonant frequency of the plates in the reaction chamber. This is likely to be somewhere in the range 10kHz to 250kHz. The resonance is shown when the gas production rate is maximised.

If the voltage produced by the throttle resistor is increased it puts more electrical energy (broader pulses) into the electrodes. Verify that a 10% mark/space ratio can be got. This will show on the oscilloscope (2 - 100 microseconds on the horizontal time-base). A digital voltmeter will display the corresponding voltage across the output transistor (measuring source to drain). reconnect the multimeter to measure current and check the current range passed to the electrodes. This should be 0.5A to 5.0A when the throttle resistor is set between its minimum and maximum settings.

When you build the circuit board, mark each connection off on the circuit diagram with a highlight pen. All variable resistors in the circuit, other than the accelerator resistor, should be of the board-mounted miniature type. The LEDs are there to give you a quick visual check of the normal operation of your circuit. You should check the operation of the reaction chamber water-level sensor before epoxying the cap in place.



The output of the 741 integrated circuit is adjusted via its 2K variable resistor, to give an output voltage (at point 'B' in the circuit diagram) of 1 Volt when the car throttle is fully up, and 4 Volts when the throttle is fully down.

The CD4069 is just an IC containing six inverters. It can handle a supply voltage of up to 18V and is wired here as an oscillator. Its capacitors are likely to be used in just four combinations: C1, C1+ C2, C1+ C2 + C3, and C1+ C2 + C3 + C4 as these are the most widely spaced tuning ranges. There are, of course, eleven other capacitor combinations which can be switched with this arrangement of four switches.

The CD4069 oscillator is used to switch the NE555 oscillator on and off in exactly the same way that Stan Meyer did. Pin 2 of the 555 IC is the trigger input and in this circuit is used to alter the frequency of the 555 oscillator as the car throttle is pressed.



The TC4420 is an 18V 'Pulse Transformer Driver' IC which is used to amplify the 200mA output of the NE555 IC to drive the electrodes. The TC4420 can handle 100 Volts at 4A continuous or 16A when pulsed and it has a 20W dissipation rating. The package connections for these ICs is shown above. Remember that you can get the specification and pin details on most ICs from the website: <http://www.alldatasheet.co.kr/>

### Important Note:

Gary of G. L. Chemelec commenting on "The HydroStar" circuit which sounds to be based on the same style of circuitry, states that the circuit and design are riddled with serious errors, some of which are:

1) The use of the 741 WILL NOT WORK! Pin 5 is a Voltage Control pin that already has its own voltage of 2/3 of the Supply voltage so it requires a pull down resistor, not an IC to control it.

2) The 2K Pulse width adjust will blow the 555 timer if adjusted all the way down. It needs an additional resistor to limit current to those pins on the IC.

3) The output of the 555, Pin 3 is fed to the CD4059 as well as a TC4420CPA (Mosfet Driver). This driver is a waste of money as it is not needed.

4) The Output of the TC4420CPA is then fed to the IRF510 Mosfet which is now obsolete, however you can use an RFP50N06 (50V, 60A).

5) There is no schematic of the CD4059. They should have shown pin 1 as in, pin 23 as out, pins 3, 10, 13, 14, and 24 connected to 12 volts and pins 2, 4, 5, 6, 7, 8, 9, 11, 12, 15, 16, 17, 18, 19, 20, 21, and 22 connected to ground.

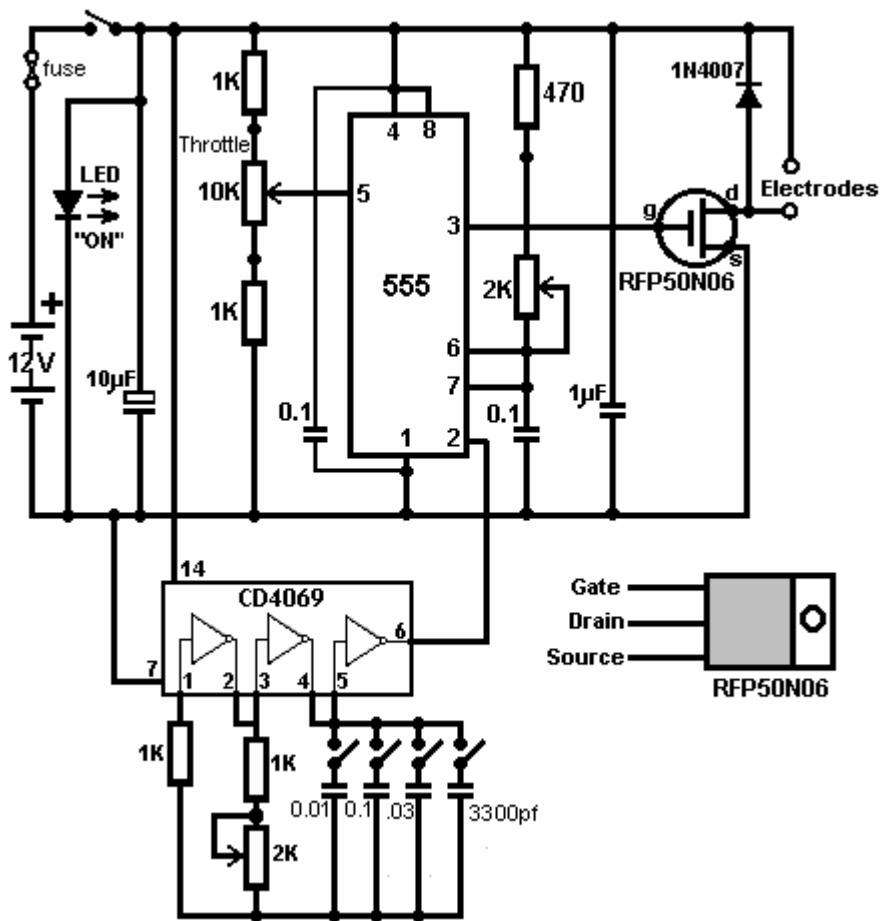
6) The "Strength Adjust" Only Needs the variable resistor connected to Pin 5 and the Ground. The Connection of this control to the Supply Voltage Make Absolutely No Difference in the Output Waveforms, as the IC only needs a 2/3's voltage on this Pin and this is supplied internally, Within the IC.

7) The "Frequency Adjust", Connects to Pins 6 & 7 of This 555. Supply to the battery Will Destroy the 555. so another resistor is needed to prevent this from happening.

This is just a small list of what is wrong. There is MUCH MORE and even after the thing is built it does NOT WORK! If you want to experiment then please do, but I would suggest you just make your own Pulse Width Modulator.

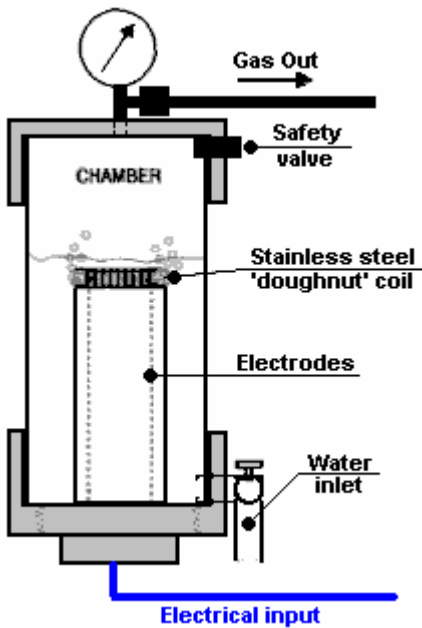
There are also many problems with the design of the reaction chamber and simply put, even if you did get it to work you would need more of these units than you could ever fit in your car to even think about running the engine. Simply put, the unit will NOT create enough gas to run much of anything. Don't get me wrong, I do think that the idea is GREAT and that it can be done.

Bearing these comments in mind, the above circuit should probably be modified and simplified to become:



**Reaction chamber:**

The suggested reaction chamber arrangement is:

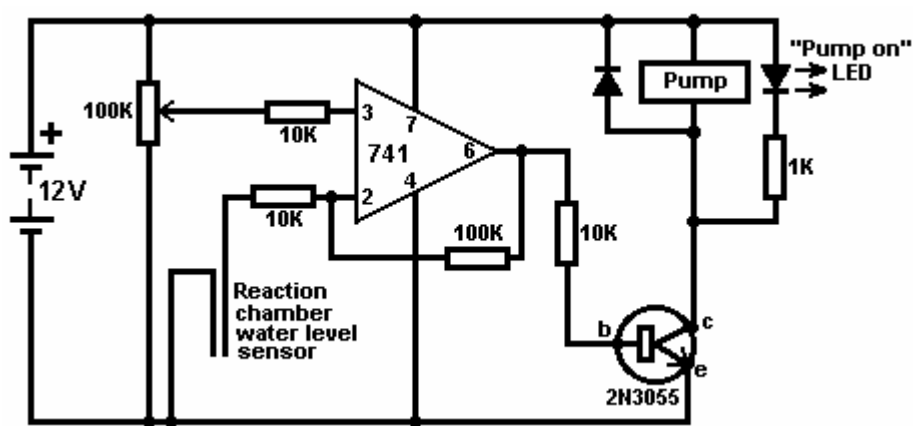


It is suggested that you use a section of 4" PVC waste pipe with a threaded screw-cap fitting on one end and a standard

end-cap at the other. Make sure to drill-and-epoxy or tap threads through the PVC components for all fittings. Set and control the water level in the chamber so that the pipe electrodes are well covered and there is still ample headroom left to build up the hydrogen/oxygen gas pressure. Use stainless steel wires inside the chamber or otherwise use a protective coating; use insulated wires outside. Ensure that the epoxy seals are perfect or alternatively, lay down a bead of water-proof silicone sufficient to hold the pressure.

The screw fitting may require soft silicone sealant, or a gasket. Its purpose is to maintain the pressure in the cylinder and yet allow periodic inspection of the electrodes. Make sure that there are no leaks and you will have no problems. Make sure you get a symmetric 1.5mm gap between the 2 stainless steel pipes. The referenced literature suggests that the closer to 1mm you get, the better. Check that the chamber water-level sensor is working correctly before you epoxy its cap in place. Make your solder connections at the wire/electrode junctions nice, smooth, and solid; then apply a waterproof coating, e.g. the epoxy you use for joining the pipes to the screw cap. This epoxy must be waterproof and be capable of holding metal to plastic under pressure.

The suggested circuit for the reaction chamber water-level pump control is:



### Carburettor connection:

There are ready-made kits (such as by Impco) available for making your pressure fittings to the carburettor or fuel-injector. You need seal the built-in vents and make a one-way air-intake valve.

The copper mesh comprises the 'inadvertent backfire' protection for the reaction chamber. This is an absolutely vital item and must not be omitted under any circumstances. A water-bubbler is another safety device and it is no harm to place one close to the engine intake. The hydrogen/oxygen gas mixture is then forced to bubble up through the water which prevents any flame moving back through the piping to the gas production area. The bubbler also adds water vapour to the contents of the cylinder and this cools the mix and can improve mileage by up to 15% even without the addition of hydrogen. A bubbler needs some form of plastic filter above the water surface to prevent water from being drawn into the engine if the car bounces around. Make sure that all gas/duct junctions are air-tight and holding full pressure without leakage. Your new 'system' is considered successful and properly adjusted when you get the full power range at lower temp and minimum vapour flow without blowing the pressure safety valve.

### Engine treatment:

You need to monitor your engine temperature with a Cylinder Head Temperature gauge and/or an Exhaust Gas Temperature gauge. Any existing temperature gauge will be too slow for this application and will not warn you against overheating until after you have burnt something. Make sure that your engine runs no hotter than in the petrol arrangement. VDO makes a Cylinder Head Temperature gauge with a platinum sensor that fits under the spark plug against the cylinder head (make sure it is really clean before you re-install your spark plug (as this is also an electrical ground)).

Get the valves replaced with stainless steel ones and get the pistons/cylinders ceramic-treated as soon as possible after you have successfully converted and run your new creation. Do not delay as these items will rust, either by sheer use or

by neglect (i.e. letting it sit). You could make maximum use of your current exhaust system by using it with your new deal until it rusts through, then have your mechanic or welder friend to fit a stainless steel exhaust pipe (no catalytic converter is required). But it could be easier and cheaper to send your existing exhaust system out for the ceramic treatment, and then simply re-attach it to the exhaust ports.

### **General details:**

Do not discard or remove any of the old petrol engine components, e.g. tank, carburettor or fuel injector, catalytic converter, etc. unless absolutely necessary. That way, you make it easy to revert to a vehicle which runs, just in case it is needed in a hurry. Some people leave their petrol set-up completely intact, and switch back and forth at will, just to have a backup plan.

Set your throttle circuit so that you get minimum gas flow at idle, and maximum gas flow at full power without blowing the pressure relief valve. This way, you control how 'lean' your mixture is by the strength of the pulse (i.e. "fatness" at the optimum pulse frequency).

If you just don't get enough power (at any throttle setting), it means that you need to:

1. Change the pulse frequency
2. Change the gap between the electrodes
3. Increase the (wetted) surface area of the electrodes, or
4. Use a higher output pulse voltage (last resort).

Always use an output transistor, such as a MOSFET, that is rated for the voltage and current you need to get the job done. OK so you might have to play around with it some. Isn't that where all the fun is anyhow?

If you get any engine knock or loud combustions (not compensated by adjusting the timing), it means that you need to install an additional coil in the chamber, and drive the coil with an additional pulse signal (about 19 Hz on the 0.1 second oscilloscope time base). Here, you will be slowing down the burn rate just enough so that the gas burns throughout the power stroke of the piston. Be sure to include a board-mounted variable resistor to set the correct strength of this second pulse signal into the coil. This is a stainless steel coil of about 1500 turns (thin wire) that you can arrange like a donut around the centre pipe (but NOT touching either electrode), directly over the circular 1.5mm gap. You want no knocking at any power/throttle setting; smooth power only, but also no excess hydrogen left over after the combustion.

Build the canister(s) as tall as you can without compromising your ability to mount them conveniently near the dash panel, or in the engine compartment, as the case may be. This way, you can always make the electrodes bigger, if necessary without undue difficulty. Remember that anything in the engine compartment should be mounted in a bullet-proof, vibration and temperature tolerant fashion.

If you have to cut a hole for wiring or plumbing through metal, be sure to install a grommet around the aperture to protect against chafing. Always watch your chamber pressure range from IDLE (15-25 psi) - FULL POWER (30-60 psi). Set your safety-pressure relief-valve to 75 psi and make sure it's rated for much higher pressures than that.

Turn the power switch off and pull off the road, if there is any malfunction of the system. Your engine will last longest when it still develops full power at some minimum temperature that we are sure you can find. Undertake periodic maintenance and inspection checks.

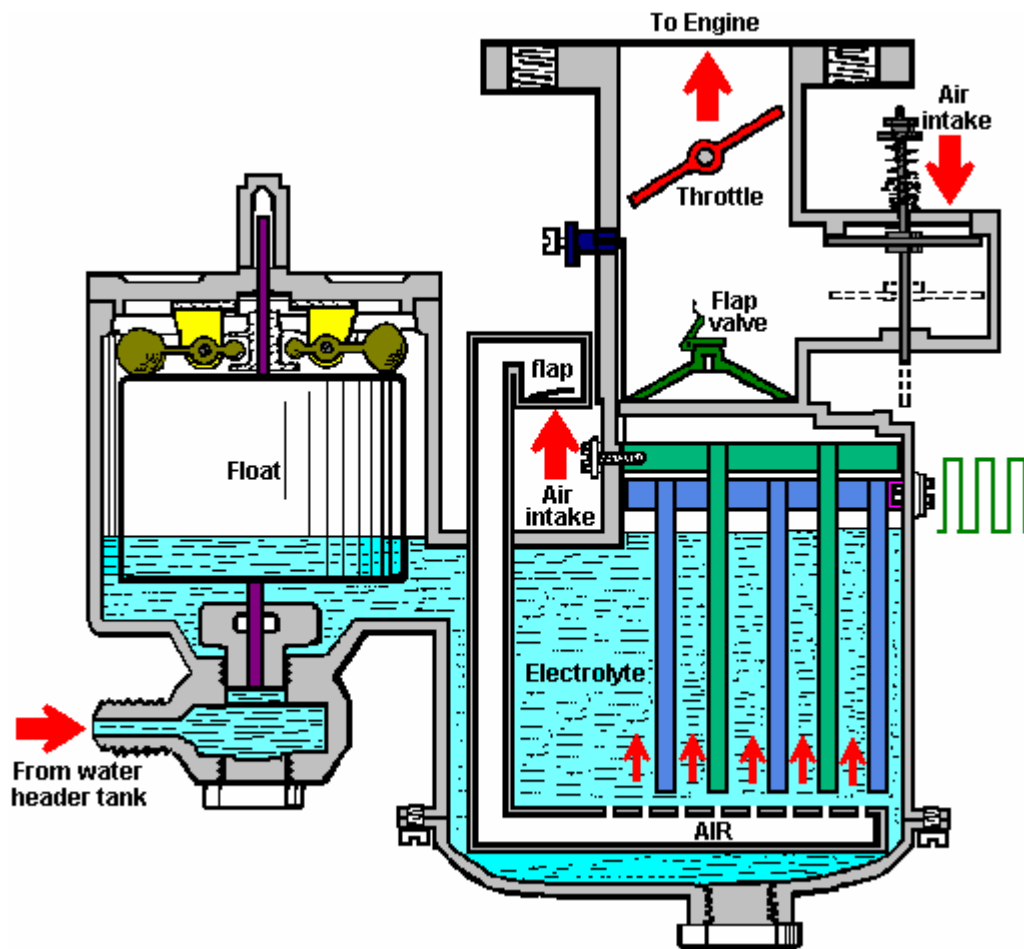
### **References:**

1. Stephen Chambers 'Apparatus for Producing Orthohydrogen' US Patent 6126794
2. Stanley Meyer 'Method for the Production of a Fuel Gas' US Patent 4936961
3. Creative Science & Research, 'Fuel From Water', [www.fuelless.com](http://www.fuelless.com)
4. Carl Cella "A Water-Fuelled Car" Nexus Magazine Oct-Nov 1996
5. Peter Lindemann "Where in the World is All the Free Energy", [www.free-energy.cc](http://www.free-energy.cc)
6. George Wiseman "The Gas-Saver and HyCO Series", [www.eagle-research.com](http://www.eagle-research.com)
7. C. Michael Holler "The Dromedary Newsletter" and "SuperCarb Techniques"

8. Stephen Chambers "Prototype Vapor Fuel System", [www.xogen.com](http://www.xogen.com)

**Tom Kramer.** Tom has placed a series of twelve very well-written documents on the web at site: [www.overunity.com](http://www.overunity.com) where they are under the name of 'Watercar'. These give considerable detail on ways of adapting existing cars to use fuels made from water and are well worth reading. This documentation also points to a very active water-car enthusiasts group at the Yahoo site: <http://groups.yahoo.com/group/hydroxy/> where the only requirement is that you register with Yahoo, which costs nothing. This group provides informed discussion and general help.

**Charles Garrett.** One of the problems with electrolysis of water is said to be caused by bubbles staying on the face of the electrodes. Charles Garrett was granted US Patent 2,006,676 on 2nd July 1935 in which he shows some impressive details.



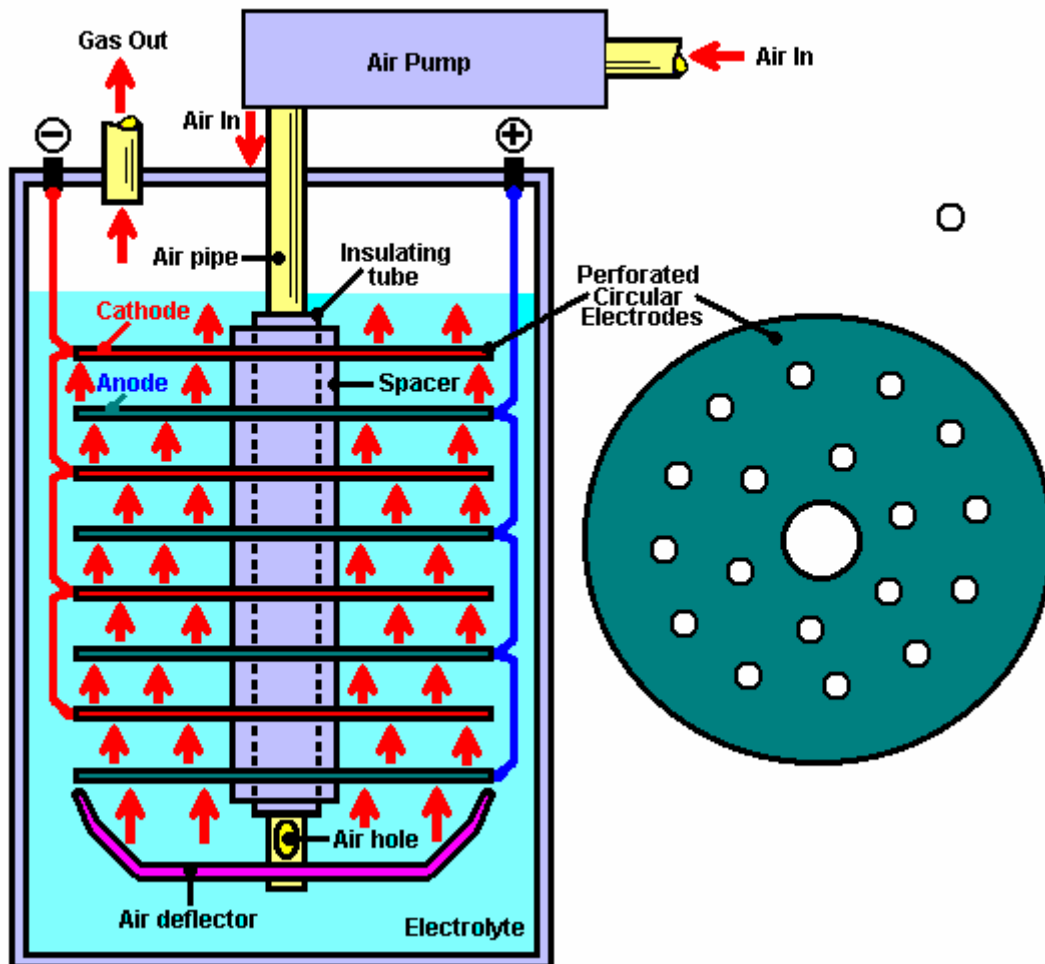
Firstly, he generates a square wave electrical input from an extra dynamo which he fits to the car. This waveform is created by mechanically swapping the electrical output terminals over at a rapid rate. He maintains the water level in the electrolysis chamber with a neat carburettor-style float and pin valve arrangement. He improves the electrolysis by introducing a perforated tube below the electrode plates which allows the engine to suck air up past the plates. This cools the electrolyte (water with a few drops of hydrochloric acid) and dislodges any bubbles on the plate, both without the need for any extra mechanical device. Considering that he did this seventy years ago, it is an impressive piece of work. Please note that while only five electrode plates are shown in the diagram, in reality it is probable that many such plates were used since the gas volume is directly proportional to the plate area.

## Archie Blue.



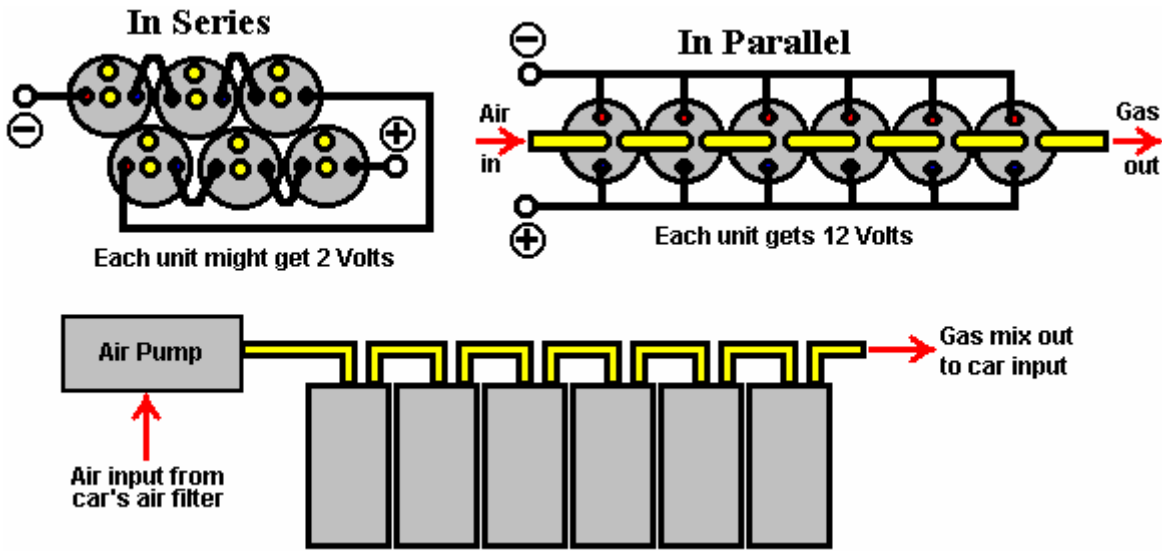
More than fifty years after Charles Garrett was granted his patent, another one was granted to Archie Blue. The equipment described in the two patents operates in more or less the same way. Archie's equipment is very simple to construct and uses straight electrolysis with no attempt at pulsing the electrical supply:

### Archie Blue's Device

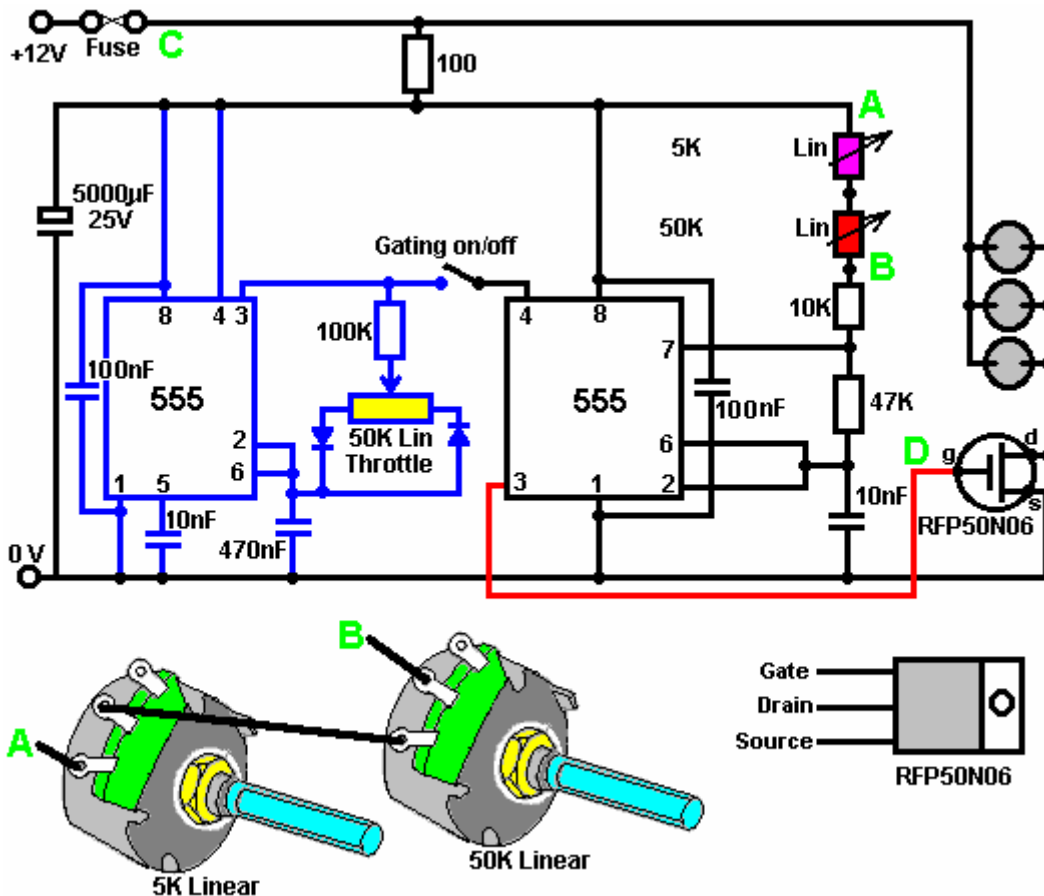


With this unit, air is sucked out of the exit pipe by the vehicle engine. This draws air down the central pipe and forces it up through the non-aligned holes in the electrode plates. The air bubbles stir the electrolyte into vigorous motion, dislodging the hydrogen and oxygen bubbles which form on the plates through electrolysis.

It is said that six of these electrolysis units are sufficient to run a car using just water as the fuel. It has been stated that electrolysis of water is optimum at 1.5 Volts, so it might be more efficient to connect the units in series where each unit receives some 2 Volts rather than in parallel where each unit receives 12 Volts:



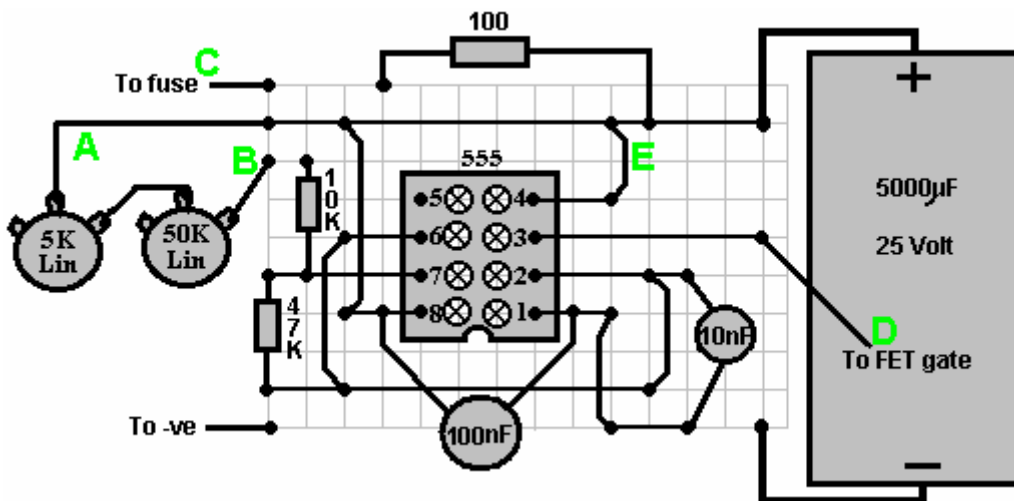
The air connection is the same for either method of wiring the cells. If wired in series, the voltage drop across each cell may not be the same although they were constructed in an identical fashion. As Paulo Mateiro got such good results with just a simple square-wave generator, these cells would probably give a much better output if they were fed a 12 Volt pulsed supply (either gated or not gated). The output of any of the circuits in the electronics section can feed the gate of a power FET transistor which then can drive the electrodes. Here is a suggestion:



This is just a crude circuit which could easily be improved by giving the 555 chips a stabilised and/or smoothed power supply of say, 9 Volts or so. The gating part of the circuit is marked in blue and is optional - Paulo Mateiro did not use one and claimed spectacular gas production.

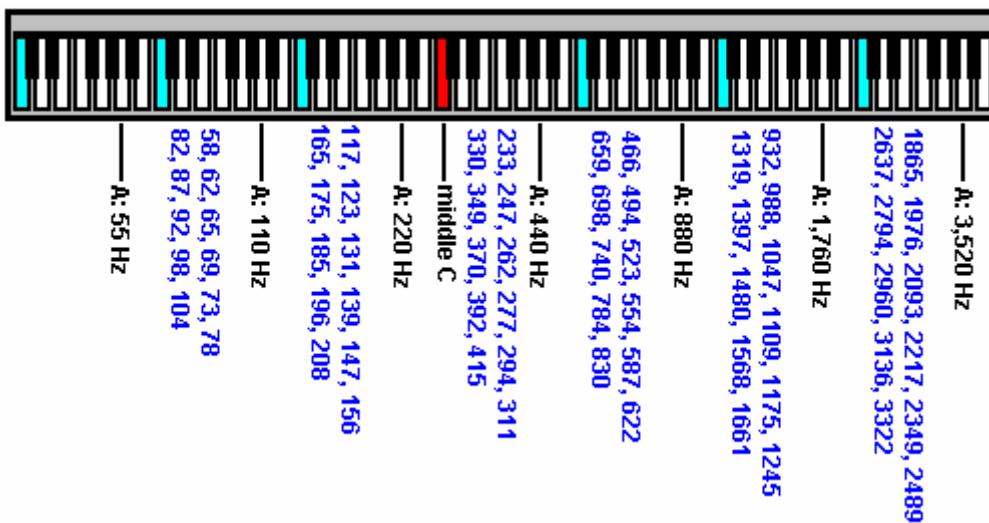
The diagram shows how the variable resistors can be wired. The 50K is marked with red in the circuit diagram and is the main frequency control. The 5K variable resistor allows fine-tuning adjustment of the frequency. Initially, set the 5K to its mid position, tune in with the 50K and then fine-tune with the 5K.

A possible physical layout for the oscillator section could be like this:



The jumper from pin 4 of the 555 chip (point 'E') which is shown going to the positive line, would instead be taken to the on/off switch of the gating 555 if gating is used.

If you wish to check the frequency of the output, just connect a loudspeaker in series with a 100 ohm resistor across the output. This allows you to hear the pitch of the note being produced. Paulo found the optimum frequency for his unit to be quite low, so if you opt for the same sort of frequency, you can use a piano or keyboard to determine the approximate frequency for any setting of the resistors:



The numbers shown in blue are the frequency of every intermediate note, including the sharps. For example, G above middle C has a frequency of 330 cycles per second or 330 HZ. Not every instrument is tuned to exact 'Concert Pitch' so there may be a minor variation for any given instrument.

Please bear in mind that should you modify a vehicle to run on hydrogen, either as an additive or as a replacement for petrol, you need to clear it with your insurance company before using it on a public road, otherwise, you will be driving without insurance since any alteration to the vehicle automatically invalidates the insurance if the insurer is not notified and agrees the change. You may, of course, modify any stationary engine or any vehicle which you only run on private property.

**Shigeta Hasebe.** Shigeta, a Japanese inventor has been granted a patent for a new system of electrolysis and the patent forms part of this set of documents. His method has given him results which are ten times more efficient than Faraday's theoretical maximum gas output. The theory indicates that his results could be twice as efficient as his already very impressive test results.



His cell uses two spiral electrodes with powerful permanent magnets mounted on them to create a magnetic field between them:

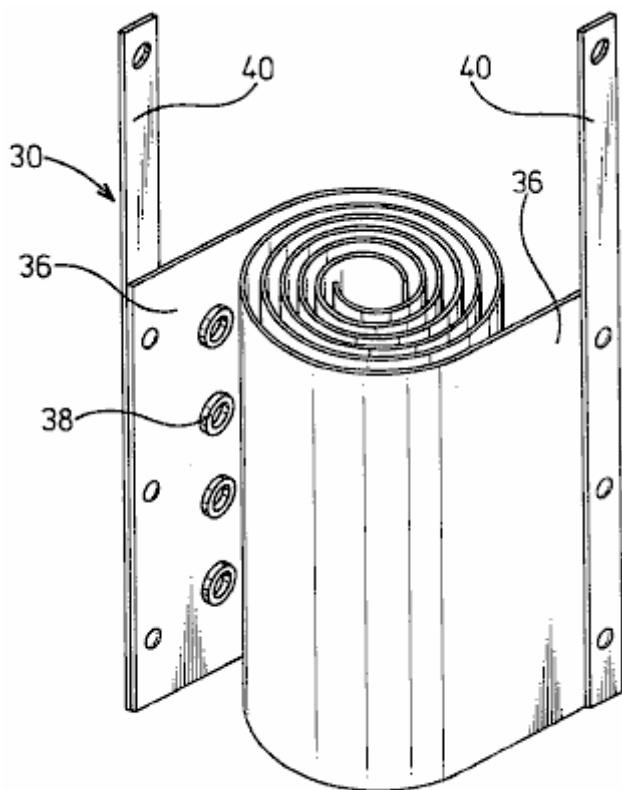


FIG. 2

Water is pumped between the plates while they are powered up for electrolysis. The water brushes the gas bubbles off the plates which keeps them operating at maximum efficiency and the magnetic field has a major effect in promoting the generation of the gasses. It is worth reading through the patent where his electrolysis cell is shown in more detail and his actual test results are displayed.

**Peter Lowrie:** Peter is developing a water electrolysis system for internal combustion engines. To date, he has managed to run a 1600 cc engine for 17 minutes on water alone. The engine block remains cool but flame comes out of the exhaust pipe, which causes it to become very hot. Also, the engine runs flat out and cannot be throttled back. Presumably, this is due to excessive amounts of hydrogen entering the engine, so a method of increasing the proportion of air in the mix appears to be needed. The really important point is that there is excess energy in the system. There are two possibilities: either the water contains energy which has not yet been discovered and documented, or additional energy is coming from somewhere else. Consider the facts:

Going into the engine you have:

- (1) Water (from the fuel tank, through the carburettor and into the cylinders)
- (2) Air

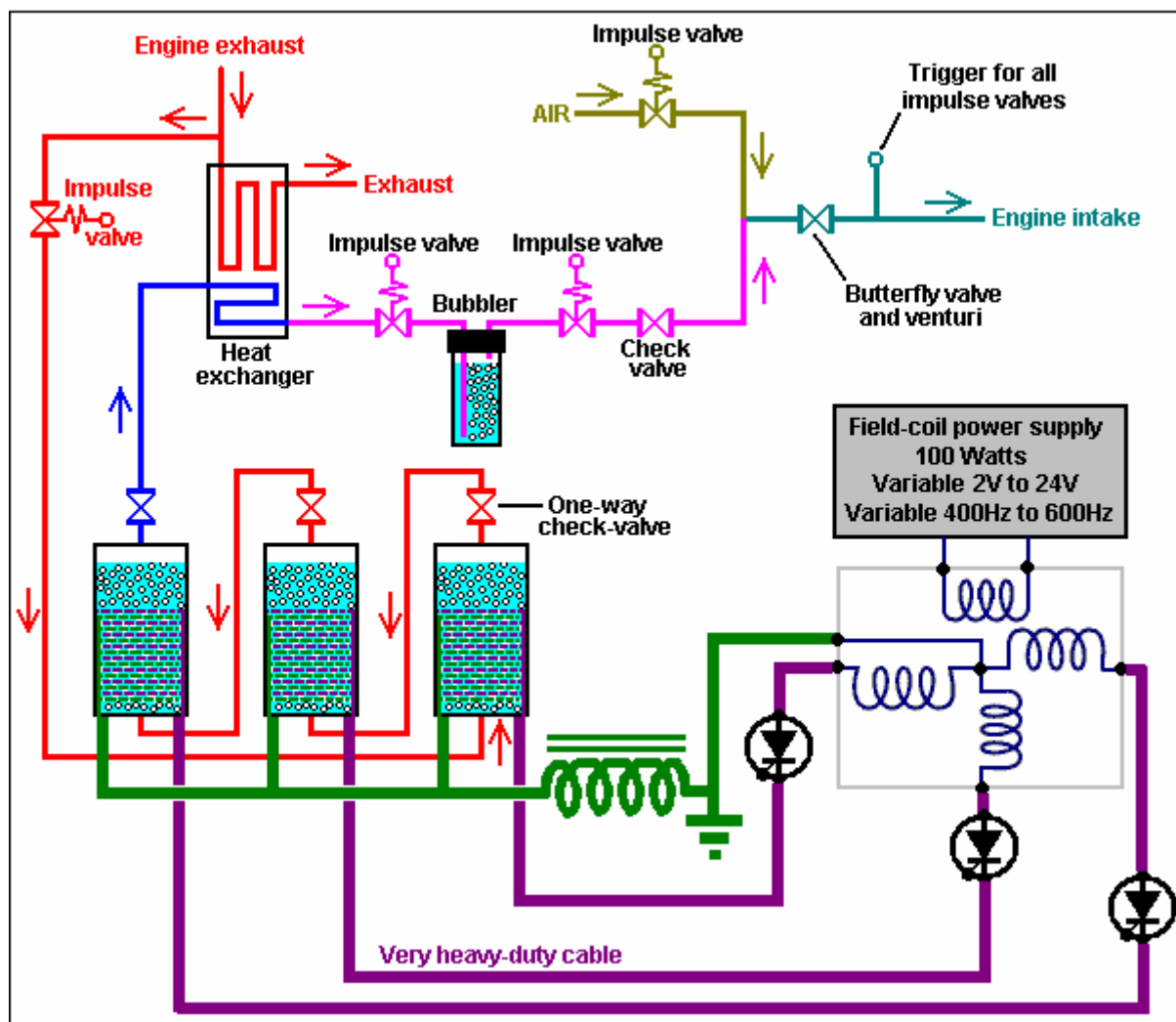
Coming out of the engine you have:

- (1) The same volume of water (coming out of the manifold)
- (2) The same mass of air (coming out of the manifold)
- (3) Large amounts of mechanical energy
- (4) Heat
- (5) Sound
- (6) Mechanical wear (it takes energy to grind metal down)

Common sense says that there is more coming out than **we** are putting in. The extra has to come from somewhere. I

think it is reasonable to call this 'over-unity'.

So, if Peter is able to run an engine 'flat-out for 17 minutes' using only water as the fuel, where is the extra energy coming from? The system which Peter is using is unusual:



Peter uses a GEC delta-wound, marine alternator which he modifies by removing the diodes and leading each of the three phase-windings out to his electronics. He uses each of the three phase-windings to power one electrolysis cell. As he only wants about 1.5 volts across each cell, he applies about 2 volts to the DC winding of the alternator, which is about the minimum for the alternator to work.

The DC current supplied is less than one amp while the pulsed current to the electrolysis cells is much higher. When a snap-on ammeter surrounds the wires to the cells, a current of 800 amps is displayed. It is likely that this style of ammeter is calibrated for sine-wave alternating current, and so the actual RMS (average) current is almost certainly different to the displayed value. What is certain, is that the current supplied to the cells is enormously higher than the DC input, and it may well be in excess of the 800 amps displayed.

A point of particular interest is the inductor placed between the electrolysis cells and the windings of the alternator. Peter describes this as a choke out of a 3-phase industrial power supply. It is comprised of a laminated steel core with a sheet of copper wound around it. This is remarkably like the arrangement used by Edwin Gray's power tube which picked up sufficient Radiant Energy to power an 80 horsepower electrical motor. Edwin's device used two or three cylinders of perforated copper sheet surrounding a conductor which was fed with 80 microsecond unidirectional pulses. This inductor is so similar in construction that it might not be unreasonable to suspect that the steel core might have very short electrical pulses induced in it, generating radiating waves of Radiant Energy which are picked up by the copper sheet winding and fed into the system providing a major additional source of energy for the electrolysis. This may well be the reason that this system produces easily enough gas mixture to run an engine.

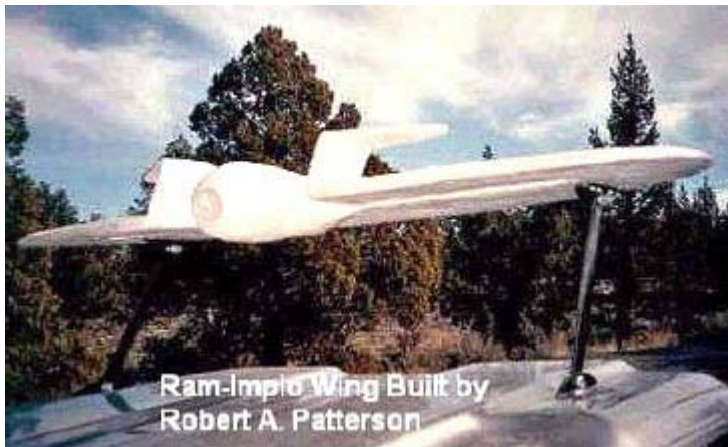
As the motor is supplying mechanical power to the alternator shaft, it is not possible to say that there is a current gain of 800 times. What is certain, is that there is indeed a pick-up of external energy in this system. This can be expected, as a

sudden pulse of large current into each cell will generate a major magnetic pulse which in turn may well tap the external energy field. This is very like the effect experienced by Ed Gray, Robert Adams, Tom Bearden, Floyd Sweet and others, when they produced large rapidly-changing magnetic fields. As remarked above, Peter's engine couldn't run on water alone without gaining extra energy from somewhere - don't forget that the engine produces the mechanical and DC power fed to the electrolysis units. To sustain the engine running, the system has to be over 100% efficient. As an Engineer, I can assure you that Peter's engine is **not** over 100% efficient, and yet it does run, which shows conclusively that it is picking up extra energy from somewhere. I expect that in the near future, we will be able to say from where the extra energy is coming.

A comment from a member of the Yahoo 'egaspower' Group: "When I joined this group in March, I saw for the first time Peter Lowerie's statement that the power out was 8 to 11 times that of the electricity required. I didn't quite believe it but thought that you might just get the engine to idle based on George Wiseman's calculations that the monatomic molecules were giving almost 4 times the energy of diatomic ones.

When I first tried it, my motor ran at the full 5,500 rpm and not at an idle as I had expected. The power generated in Peter's mode of operation is about 39 times what you put in if you allow for the fact that the motor is only about 25% efficient. I then loaded my motor to the full rated load and found that there was no lack of power. I have not completed the last step of returning the exhaust to the input of the cells, but I have every confidence that what he says he is doing is indeed a fact."

**Ram Implosion Wing:** The next device may not be a "free-energy" device as such, but if not, it is very close to being such. It is a structure, which when mounted on top of a motor vehicle, improves the airflow to such an extent that the fuel consumption is said to be reduced by a major factor. The device was invented by Robert Patterson and is said to create a vortex which not only decreases wind resistance but may also create a forward propulsion force.



It is claimed that the effect created by one of these wings reduces the amount of dust stirred up when driving along a dirt road and if there is a paper bag sitting in the middle of the road, it is left unmoved when the vehicle passes over it at high speed. About a dozen people are testing this device at the present time. The biggest effect is at speeds of 60 mph or more. One researcher states that he installed the wing on the roof of his Lincoln Town car using a roof rack which allowed the wing to hang over the rear window by some six inches. He claims that his fuel consumption has improved from 17 mpg to 56 mpg.

Positioning of the wing, texturing of the wing surface, and the speed of the vehicle appear to be important factors in gaining an improvement. There is a research group and the website is in the 'websites' file and is at : [http://www.pureenergysystems.com/news/2005/03/08/6900067\\_RamWingUpdate/](http://www.pureenergysystems.com/news/2005/03/08/6900067_RamWingUpdate/)

**Fuelsavers:** A similar system is on offer from the website <http://www.fuelsavers.com.au/> where they offer small aluminium fins which mount on top of the trailing edge of the bodywork of a vehicle. The devices are reckoned to save some 10% to 12% on fuel consumption, they can be home-made, nine per vehicle is the recommended number. The device and mounting look like this:



A "Fuelsaver"



The mounting method

**Do-It-Yourself Car Conversions:** Again, while this is not free-energy information, there is a web site offering information on practical self-installed car conversions to run on natural gas, or various other readily-available gas types. The information appears to be very practical and well presented. This site also offers information on making your own low-cost, solar heating and solar cooling systems so I suggest that a visit is worthwhile.



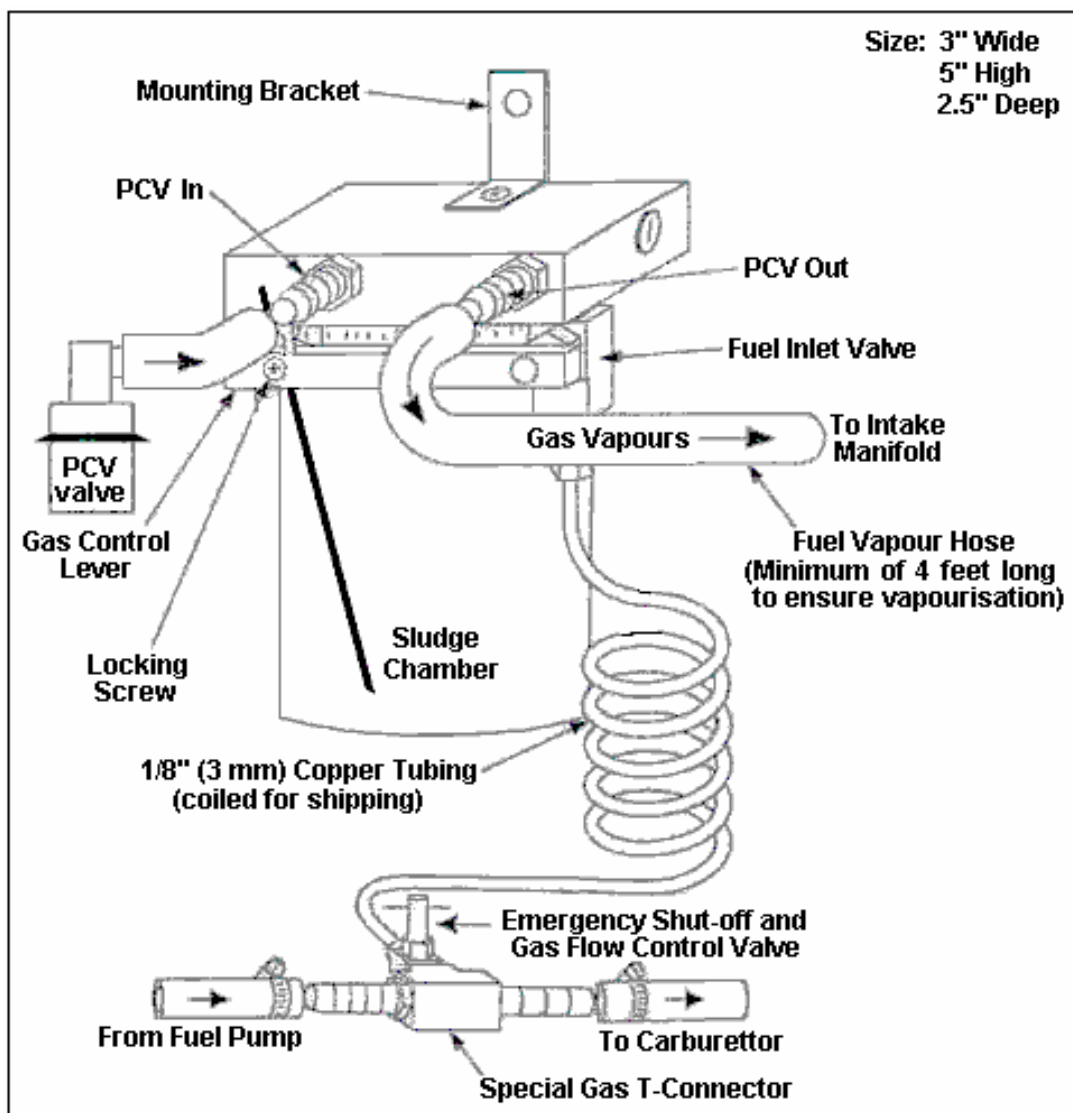
The URL is [www.knowledgepublications.com/hydrogen\\_car\\_dvd/h2\\_car\\_dvd.htm](http://www.knowledgepublications.com/hydrogen_car_dvd/h2_car_dvd.htm) and is in the 'websites' section of this data.

**Wyoming Instruments.** Since 1991, Wyoming Instruments have been marketing a device called the "Fuel Atomizer 2000" which is claimed to improve fuel consumption, reduce emissions, improve performance and reduce engine wear. They are so confident of their product that they offer a 60-day money back guarantee should any customer not be satisfied with the performance of the device. They quote improved mileage for six vehicles, ranging from 34% extra on a 1993 4-litre Nissan to 140% on a 7.5 litre Ford pickup.

It is stated that one vehicle with 100,000 miles on the clock, failed its emissions test. Four weeks after fitting the device, the test showed lower emissions than would be expected on a new engine. The device can be switched from vehicle to vehicle and works on engines with carburetors and on injection engines. However, it does not work with diesel engines.

It does not produce a leaner burn but instead provides a better atomisation of the fuel entering the engine. It is easy to fit, has no moving parts and only one adjustment. The device turns the liquid fuel into vapour which is then fed into the intake manifold. The liquid fuel flow is decreased to compensate for the vapour added. It would be reasonable to expect a minimum of 20% improvement in fuel consumption when using one of these devices. The price in winter 2005 is quoted as US \$75 on their website but their Sales division states that the price is \$150 and that there is no UK distributor. Their web address is: [www.wyominginstruments.com/gas\\_home.htm](http://www.wyominginstruments.com/gas_home.htm)

The device looks like this:



### Summary:

Please be aware that should you alter your car in any active way, such as adding hydrogen gas to the air intake or converting it to run on natural gas, then it is essential to inform your insurance company. Should you be involved in any form of car accident and the insurance company has not been informed of any change, the insurance company will deem your vehicle to be without any insurance cover whatsoever. May I also stress again, that if you decide to make any modification to your vehicle or to experiment with hydrogen, you do so wholly at your own risk and responsibility. Hydrogen is quite unlike petroleum vapour, with flame speeds some 1000 times faster and it forms a highly explosive mixture when mixed with oxygen (either from electrolysis of water or from the air). If released indoors, hydrogen will collect on the ceiling and be a serious hazard until the room is fully ventilated. I strongly advise you to avoid hydrogen production, but if you decide to do it against my advice, please take every safety precaution and be under no illusion as to the power of what you are producing.

It appears that there is scope for improvement in vehicle efficiency and the possibility of eliminating petrol altogether as a fuel for engines:

1. If hydrogen is generated by electrolysis powered by a petrol engine, and then fed into the engine along with the air, the petrol vapour burns far more efficiently. This increases the miles per gallon and reduces the pollution of the exhaust. Such a system is a reasonable Do It Yourself project. If the electrolysis is particularly efficient as in the case of Bob Boyce, then fuel oil can be dispensed with altogether - but remember that parts of the engine and exhaust will tend to rust if you do not use any fuel oil at all.
2. For higher speed driving, the addition of an aerofoil on top of the vehicle is said to reduce the wind resistance by a major factor and so reduces the fuel consumption further.

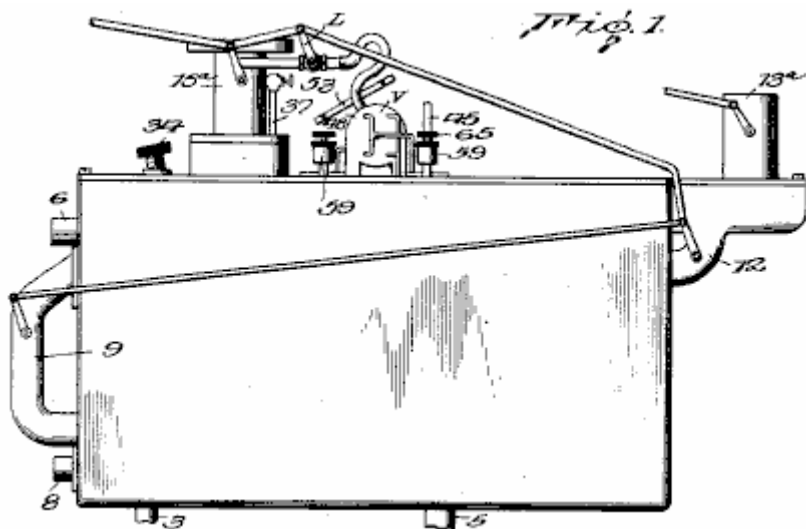
3. If outside energy can be tapped when electrolysing water (as per Stan Meyer and Peter Lowrie), sufficient volume of hydrogen can be generated to run an internal combustion engine without the need for petrol. This system will cause rust problems unless the engine and exhaust components are upgraded. It should be noted that it is not easy to produce a reliable low-current water-splitter system, like Stan Meyer did.
4. It is possible to run an internal combustion petrol engine on water alone, using the same technique as "s1r9a9m9" where water vapour taken through the carburettor turns to steam inside the cylinder during the compression stroke, and then is converted to 'flash steam' by a high-plasma spark. This also will cause rust problems unless the engine and exhaust components are upgraded.

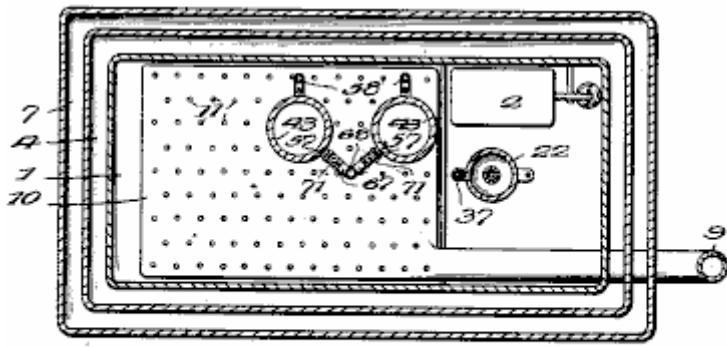
One thing should be made absolutely clear: the difficulties in producing and marketing free-energy devices or any device which makes a major impact on a vehicle's mpg, is political and economic, and most definitely **not** technical. We do not have an energy crisis, we have a political/big-business crisis. There **is** no energy shortage. Many, many people have produced devices which provide unlimited energy without the need for conventional fuels but they have not been allowed to market them. As this document deals mainly with vehicles, take the case of carburettors which are much more efficient than the current models. There have been designs around since the 1930's which will enable a vehicle to cover up to 200 miles per gallon. The big oil companies just will not allow these to be produced and will use any means whatsoever to prevent production. While 200 mpg is possible on the more efficient engines, vehicles which can only cover 8 or 10 miles per gallon, will not reach the very high mpg figures. A more realistic target would be somewhere between two and four times the previous performance, say 20 to 40 mpg instead of 8 to 10 mpg.

Another point of note is that in USA, gasoline today is not the same as it was when most of these carburettors were designed and built. Today, it contains additives which will not vapourise and burn. Consequently, a thick residue will build up inside a high-efficiency carburettor as they generally operate by converting the fuel into vapour before feeding it to the engine. This is what causes the removal of the additives inside the carburettor, generating the residue which will require removal from time to time. This set of documents includes several patents for carburettors which give massively increased mpg.

For example:

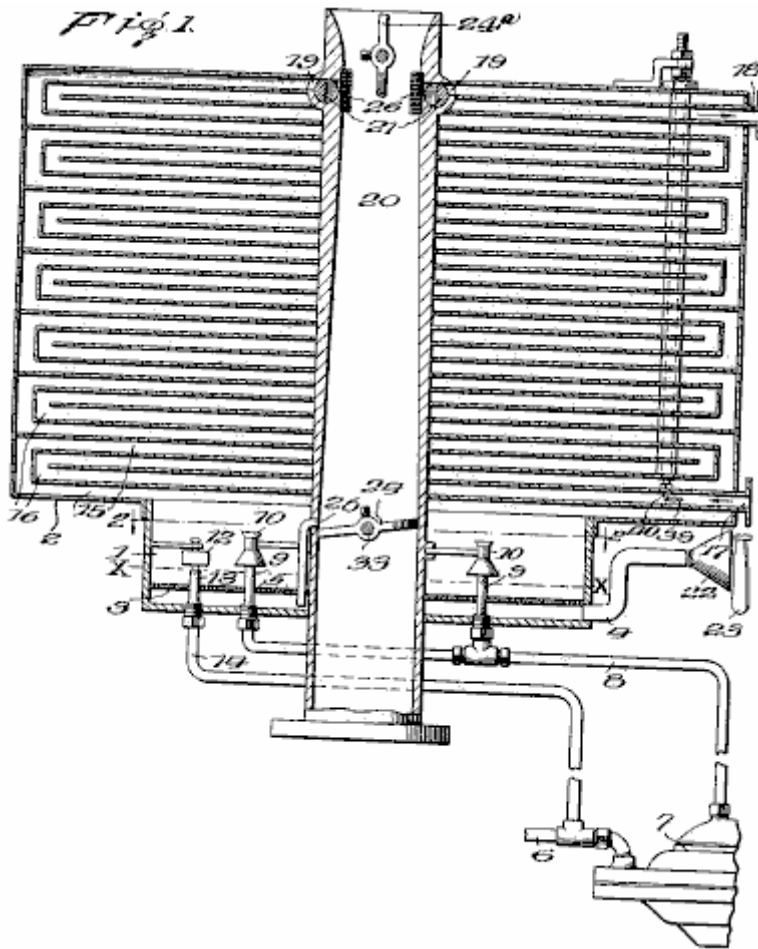
Charles Pogue's patent 1,938,497 dated November 1932:



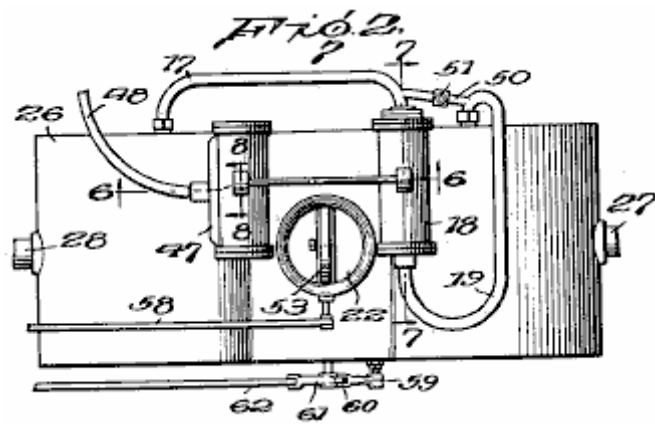
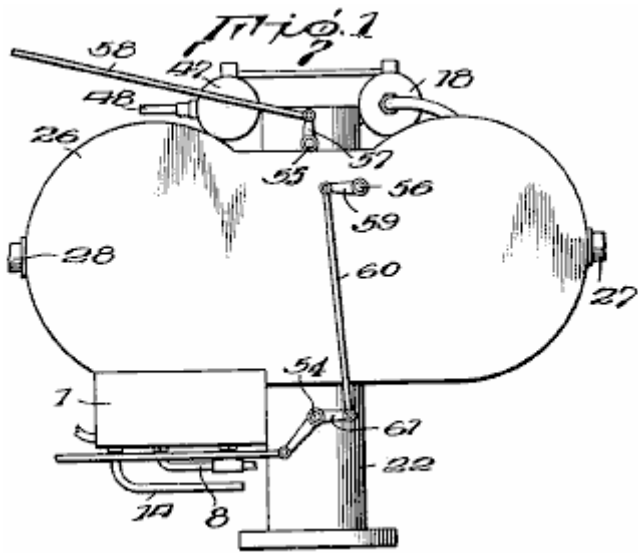


*Fig. 3.* Inventor  
Charles N. Pogue,

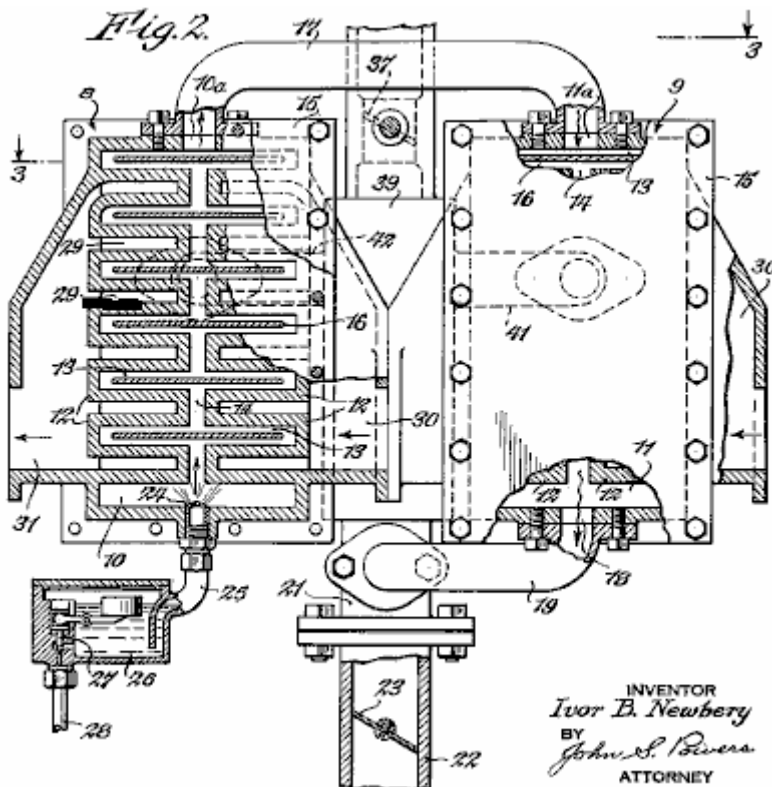
Charles Pogue's patent 1,997,497 dated November 1934:



Charles Pogue's patent 2,026,798 dated September 1935:

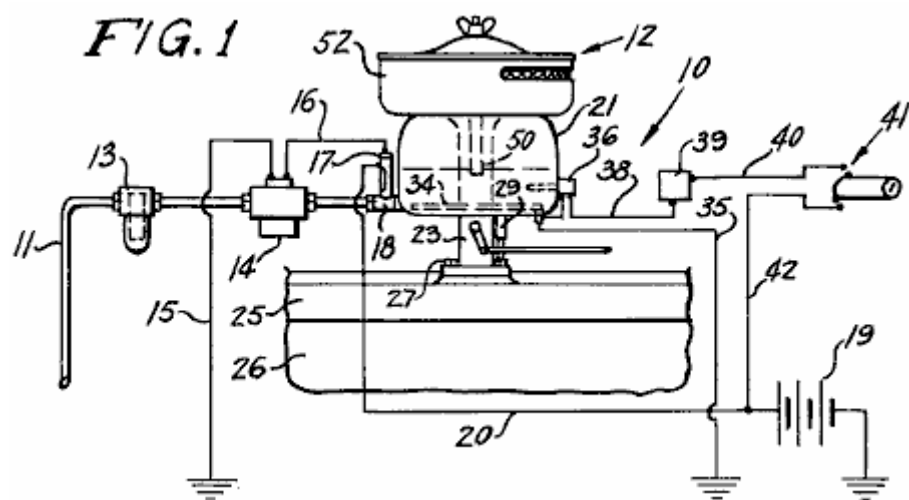


Ivor Newberry's patent 2,218,922 dated June 1938:

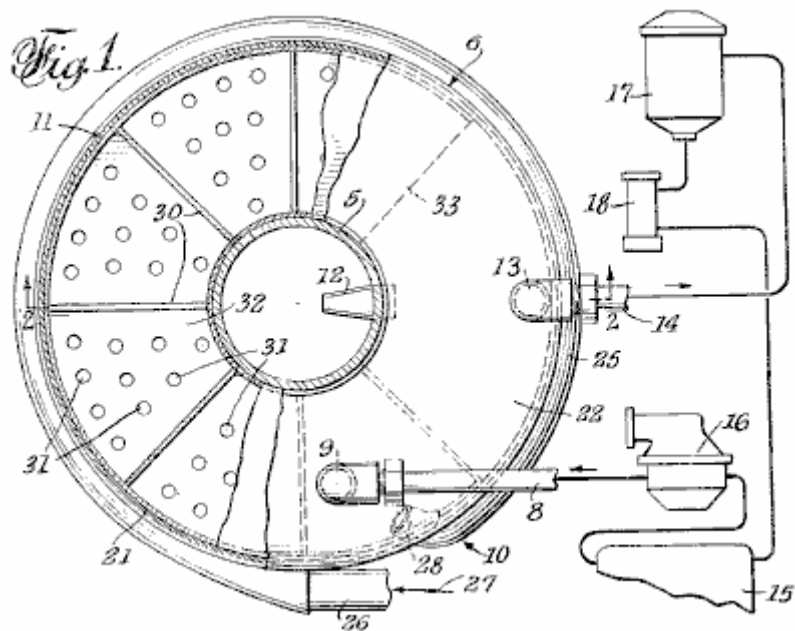




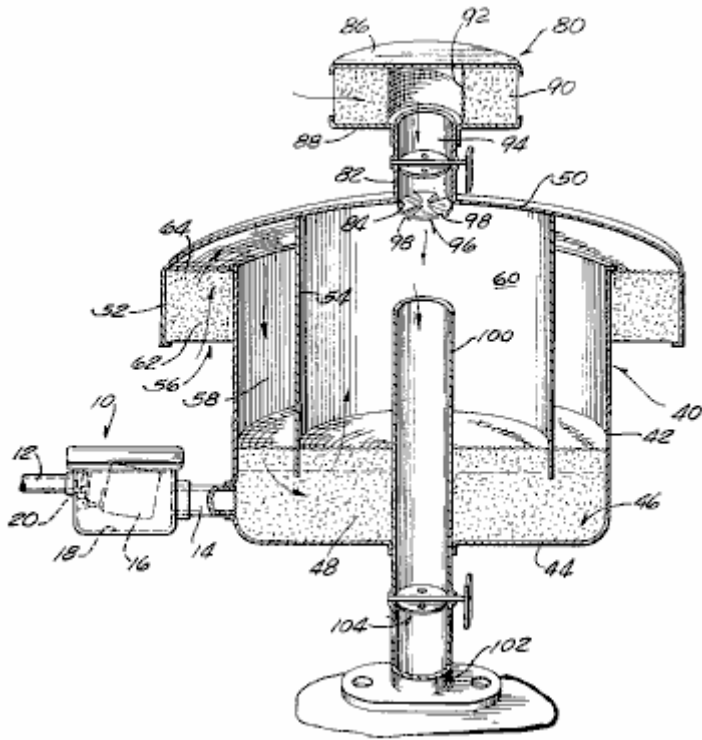
Robert Shelton's patent 2,982,528 dated June 1958:



Harold Swartz's patent 3,294,381 dated March 1963:



Oliver Tucker's patent 3,653,643 dated April 1972:



It has been suggested that the additives put into US gasoline prevent carburettors like this from functioning correctly, leaving a residue behind them. However, in 1997, an engineer working at a US Ford company plant witnessed a 351 CID V8 started at about 4:30 pm. with a 1 litre bottle of fuel. The next morning when he went to the factory floor, that engine was still running and had only consumed about one third of the one litre bottle. On asking about the fuel consumption, he was shown a display that read, " 248.92 mpg". He was shocked and said, "This must be a mistake" but the engineer said that it was true. He then asked when they would have it ready to be put in a new Ford, he was told that he would NOT see it in his lifetime. That 249 miles per US gallon is 298 miles per European gallon which is 20% bigger than the US gallon.

The high-mpg carburettor designs shown above and in the 'Patents' section, have not been marketed due to opposition from the oil companies. You are entitled to construct them for your own use as soon as the patent is published. To the best of my knowledge, the period of patent protection (against others manufacturing and selling your design) extends for just seventeen years, so all of these patents have expired and consequently, you may manufacture and sell them without paying royalties. The question is - are you that brave?

If you think that this is exaggeration, take the case of Allen Caggiano whose high-mileage carburettor patent and constructional details are included in this set of documents.



Allen is an inventive and stubborn man not readily blackmailed or browbeaten. In 1978 he produced the design for his first high-mileage carburettor, assembled the prototype and installed it in a 1973 Dodge Coronet station wagon. This gave spectacular results of 111 miles per gallon. Unfortunately, it failed after a short time. In 1979, he installed the second generation device on a 318 cubic inch Dodge V-8 engine and called it the "FIVS Gen II" standing for "Fuel Implosion Vaporisation System Generation 2". This second prototype proved very reliable and produced results as remarkable as the first, getting as much as 113 miles per US gallon (European gallons are 20% larger than US gallons so 113 miles per

US gallon is 135 miles per European gallon).

The installation of the 'FIVS Gen II' required modifications to the carburettor and the removal of the catalytic converter. This was prohibited by EPA regulations. It was therefore a violation of Federal Law. Al ignored the regulations because he knew tail pipe emissions from his FIVS vehicle were much lower than the law required. He was upholding the spirit of the law, and he was willing to argue his case in court if it came to that. He wanted a confrontation, he wanted a chance to tell the world that his FIVS made pollution control devices obsolete. He painted the station wagon bright yellow and in bold black letters along the sides he wrote: "This Car Gets Over 100 Miles Per Gallon and Doesn't Pollute the Air".

On the third day of his new campaign, as Al got into the station wagon he noticed a car pulling up behind him. He got out to greet two men in suits flashing FBI credentials. While he spoke to one, the other slipped away, climbed in to his station wagon, and drove it off. Astonished, he turned to watch his vehicle going down the street. Then he heard the FBI car pulling out behind him. Al just stood there watching the two vehicles disappear around the corner. An old friend, his attorney, later called the FBI office. The FBI denied any knowledge of the incident. Angry and frustrated, but undaunted, Al said good-bye to the Dodge Coronet, and found another similar Dodge station wagon and set to work installing another FIVS system. He painted this one yellow, too, with bold black lettering.

Not long after the first car was stolen, he received an interesting offer from a California based corporation. This corporation wanted to purchase exclusive rights to his FIVS Gen II. Al asked his attorney to check it out. The corporation turned out to be a subsidiary of several other corporations, all of which were owned by an oil company. This arrangement is typical of the way contemporary monopolies are structured. Al had been doing some reading about other inventors in the past and other fuel saving devices that had never seen the light of day and he was determined that he would never allow the oil companies get control of his device.

After he refused the offer, two different FBI agents came calling. He was careful not to leave keys in his unattended vehicle this time. They informed him that he was violating Federal laws and should cease and desist. Defiant and excited that he might soon make his case in court, he told his wife, Deb, not to worry. A couple of weeks after the second FBI visit, unmarked brown paper envelopes began arriving, containing 8" x 10" photographs of the children and Deb. A child on the playground at school. A child getting off the school bus. Deb in the supermarket, and so on. She was terrified and the marriage broke up.

The FBI was behaving like the Mafia. He wrote on the side of his Dodge: "The Big Boys Are Trying To Make Me And This Car Disappear! HELP ME!". One his oldest friends, his attorney, who was like a brother, refused to have anything else to do with him: "Wake up!" his attorney said, and then abruptly hung up the phone.

The Feds weren't going to give him his day in court to defend his FIVS. They had stolen his first prototype vehicle and they knew it worked as claimed. He had refused to relinquish his control, so they were going to send him to prison, but not for violating federal emissions regulations. On the face of it, the Environmental Protection Agency appears to be imposing regulations on the auto makers and the oil companies in the public interest of protecting the quality of the air we breath, and the quality of the air we breath is improved over what it used to be. But in fact, these special interests often write the legislation themselves. The regulations then create a profitable new area of business which allows the special interests to increase their control over the market. The public interest is best served by creative innovation in a free market. Al was learning Politics 101 the hard way. In the business of vehicles and oil, there IS no free market. In a monopoly-controlled market, there are anti-competitive regulations, dirty tricks, and active suppression. The Big Boys protected their turf and took control of or destroyed any potential competition in the hallowed tradition of John D. Rockefeller Snr. and the Robber Barons of the past. That wasn't hard to understand. But he was unprepared for the sophisticated tactics of today's faceless Robber Barons.

The Chief of Police for Brockton, planted stolen cocaine in Al's home during a drug raid that ultimately put Al in prison in 1986, for 15 years on a cocaine trafficking conviction, in spite of the fact that Al didn't use drugs, nor associate with those who did. He fought back. In prison, he fashioned a key in the prison shop and simply let himself out. He contacted a friend on the police force and then turned himself in on the same day. This police officer friend was able to uncover evidence of the chief's corruption. Two days later, the Chief was arrested for stealing cocaine from the evidence locker, most of which he had taken home to feed his addicted wife. He went to prison himself, which led to the reversal of over 300 drug convictions that had been decided during his tenure. The Massachusetts Supreme Court of Appeals overturned Al's conviction. For a moment, he thought he'd beaten the Big Boys and was a free man again.

But then the Federal Prosecutor stepped in and indicted him on new charges relating to the seizure of two shot guns during the phoney drug bust. A spurious interpretation of the US Code was applied. Al was sentenced to a total of 30 years in Allenwood Federal Prison, without parole.

Al's time in Allenwood was not wasted in self-pity or bitterness towards the Big Boys or the corrupted system that put him there. He was popular in Allenwood right away because of his role in exposing the dirty cop that overturned so many drug

convictions. He developed a good relationship with the warden of facilities. As a licensed HVAC contractor, Al was able to fix the prison heating and cooling system that had never worked properly, saving the government a large amount of money. Honeywell Corporation trained him in the use of computers so that he could operate and maintain the system. The prison had an excellent machine shop which allowed him to continue working with his FIVS devices. He designed small FIVS for the prison lawn mowers and produced numerous FIVS GEN II's, with the collaboration of the warden of facilities, that were secretly distributed outside.

Al made many useful contacts, one of whom helped him secure US Patent 5,782,225, awarded July 21, 1998, for the FIVS Gen II. He designed a new FIVS, the "Gen III", which did not violate any Federal regulations, and he put together a plan to manufacture and distribute the Gen III. And then one day he was out, free for real in 1997. Sentenced to 30 years without parole, he was suddenly released after ten years with five years parole. The Federal appeals court had finally ruled that his possession of two shotguns was legal and that it had no jurisdiction over the matter in the first place. Several years later, because he was curious, he asked a police officer friend to do a background check on him. No record of his conviction and incarceration in Allenwood was found. The stain of systemic corruption had been discretely removed.

He didn't look back and went to work to develop a prototype Gen III device, applied for his new patent, and implement the strategy he had dreamed up in prison. He was no longer politically naive, no longer the blindly patriotic American he'd once been. He did not believe it would be possible to build the Gen III in the home of the brave and the land of the free, so he made arrangements to manufacture parts in the Ukraine, a former satellite of the defunct Soviet Union. He would then assemble the devices in Mexico. He had developed a global perspective in Allenwood. His network of supporters and investors was now called: "FIVS Gen III International" and he set up a website which was generating 70,000 hits a month from all over the world. He also offered the complete blue prints for manufacturing the earlier FIVS Gen II as a free download from his site so that anyone who wanted to could build their own. He thought this might distract the Feds and tie up their manpower as he implemented the Gen III strategy.

By 2002, the delivery date for the first beta testing group was set. The parts were shipped from the Ukraine to Mexico where they were assembled. It was necessary for Al to travel South of the border to oversee the operation. He made the punishing drive from Massachusetts to Mexico several times in his FIVS equipped Pontiac Catalina and it functioned flawlessly, delivering more than 70 mpg with its 400 cubic inch engine. His friends warned him not to drive alone, but he made the last trip by himself and on the return leg of the journey, he noticed an 18-wheel truck following him. The intentions of this truck were soon obvious when it overtook him and forced him off the road. Al anticipated the manoeuvre, however, and was able keep control of the Pontiac. He breathed a sigh of relief and continued on, believing he'd outwitted them once again. He made it all the way to Massachusetts and was nearly home again before the truck found him a second time and caught him unawares. The Pontiac rolled over several times, but landed upright. The driver's side door was crushed and the roof caved in, but the car still ran and Al was able to drive it home without further incident in spite of his injuries. He had to be cut out of the car with a torch. He had several broken ribs and a punctured lung and was immediately rushed to hospital.

The Gen III's for the first group of licensees were shipped from Mexico on time, however, by means of several different shippers. Some devices for US licensees were shipped via United Parcel Service. A total of 137 units were shipped around the world. Only those that went UPS in the continental US and Canada, a total of 44 units, did not arrive at their destinations. Every shipped item has a tracking number, of course, and when Al inquired about the missing 44 units and provided the tracking numbers he'd been given, he was informed the numbers he had did not exist.

The attempt to turn him into road kill was not completely unexpected, but Al was shaken just the same. He maintained his bravado, however, while friends and sympathisers reacted more predictably. When the intent of the suppression escalated from malicious to deadly, most began to slip quietly away and it was 'High Noon' again. Another complicating and aggravating factor was the appearance of a discussion group at the Yahoo website called "Get 113to138mpgNOT". This Yahoo Group was established by an individual calling himself "David Rodale". He was not a Gen III licensee. He (or she) was a freelance public servant dedicated to helping those who had been ripped off by the promoter of impossibilities, the unscrupulous scoundrel, Allen Caggiano. He provided advice and counsel to those disappointed licensees who had not received their Gen III devices. He assured them that they could find justice in the courts. Al spent much time and energy fighting back against this defamation.

Al was fully recovered from his "accident" by this time and had repaired the Pontiac. He was feeling every day of his 59 years, but he soldiered on with a grim determination towards whatever final confrontation awaited him. When a careful, bloodless voice on the phone proposed a compromise one day, he felt ready to bargain. His website was experiencing growing traffic. The voice told him that if he would just remove the Gen III from his site he would be left alone. It felt like a small victory, but he didn't relish the idea of backing down. If Gary Cooper had received such an offer in High Noon, he would have taken it.

He knew a bargain with the devil could never work in his favour, but he had to catch his breath, so he played along and

removed the Gen III from his web site. It was a strategic retreat. If they would leave him alone, the beta testing of units already out there could go forward. The program was smaller than he had originally intended, but it was a start and if he could relax and gather his data, then he might ultimately win the game. However, a careful examination of the FIVS in his Pontiac one afternoon made his heart jump into his throat. He found a tiny hairline crack in the aluminium/titanium alloy cannister. This Gen III unit had many thousands of miles on it. It presaged a potential disaster and he immediately notified all the licensees of the problem and recalled the units. He worked feverishly and discovered that he didn't have to redesign the cannister. A simple alteration appeared to be the solution.

Al was then told that he required immediate surgical treatment. After the fact, this prognosis was shown to be false. While the surgery was underway, Al suffered a stroke. His heart stopped and he was technically dead on the operating table. In addition, the surgeon had damaged nerves in his spinal column. It was not his time to go, however, and he revived, but then lay in a coma for 30 days. When he finally came around in his hospital room, feeling more dead than alive, he was astonished to discover that he could not move his legs. It is possible, that Al's medical experience was not accidental.

On the local TV noon news on a sunny day in the spring of 2003 he watched a dramatic live report of a SWAT team in action. They were closing in around a familiar looking building. He thought to himself: "Hey! That's looks like my condo! Hey! That IS my condo!". He watched the police seizing his yellow Pontiac in the parking lot as the Channel 7 reporter explained that Chelmsford, Massachusetts, resident, Allen Caggiano, had defrauded investors in a fuel saver scam and then fled the country. He didn't see how that could be true since he was in the Intensive Care ward of the local hospital, not 20 miles away.

Meanwhile "David Rodale" at Yahoo Group "Get 113to138mpgNOT" had found 20 disappointed Gen III licensees and was patiently building consensus for legal action at the state level in Massachusetts. It wasn't easy to turn disappointment into outrage and a desire for revenge. In spite of the resources available to the Big Boys, they hadn't been able to otherwise identify most of the testing program licensees. Al returned home to his condo to find his Pontiac with the repaired Gen III's in the trunk gone from its parking space. His premises had been ransacked, his computer hard drives removed. With his mind foggy from pain killers, Al tried to concentrate on getting used to a wheelchair. Nurses from the Visiting Nurses Association were with him around the clock. Gradually he stopped using the pain killers. He began to notice sensation returning to his legs.

Even as he felt himself improving, his diabetic condition inexplicably worsened. Twice he was rushed to the hospital in a comatose state. The third time this happened, a nurse checked his pill box and discovered insulin pills that should not have been there. He was now taking insulin through injection, but the old insulin pills were still in the medicine cabinet and had been put in his pill box with his other medications. The result was insulin shock. The nurse, Michele, who had done this, not once, but three times, did not again appear for her shift. Al tried to reach her to ask for an apology for her mistakes, but she had vanished. The Visiting Nurses Association denied having any record of her employment.

"David Rodale" was having success convincing the disappointed licensees to file suit, and with the newly acquired information about the FIVS Gen III International operations taken during the SWAT assault, a postal inspector launched a preliminary inquiry into the feasibility of action at the federal level for mail fraud. Rodale was confident that the threat to society posed by Allen Caggiano was now neutralised. He announced to the Yahoo Group members that he'd done his best and there was nothing more to do. He would leave the Yahoo Group in place for a while, but he planned to take it down in a couple of months. He was sorry that so many people had been taken in, and he hoped they'd be less gullible in the future. He was glad he could help.

That summer, the judge dismissed the charges against Al in the Massachusetts court. His lawyer petitioned for the return of his property, the Pontiac the local police had seized a year earlier. He was told it had been taken to Washington, DC, and was being examined to determine if it violated any Federal regulations. A grand jury in DC was convened to investigate the Federal charges of mail fraud, but it failed to return an indictment. The licensees who had paid their money and signed their licensing agreements had agreed to assume the risks of a testing program and most of them did understand that part of the risk involved the historical efforts of the oil/auto cartel to suppress new technology that could affect their profitability or control over the markets which they ruthlessly dominate.

Through his attorney, Al received an offer for exclusive rights to the Gen III. The amount of money involved beggars belief, and suffice it to say that Al again refused, as he had done in the early 80's when an offer was made for the Gen II device. The Big Boys have never attempted to prosecute him for the violation of Federal Emission Control regulations. He is clearly guilty on this score so far as the Gen II is concerned. To do so would result in the exposure of the fraud they are perpetrating on the public. Their technology is obsolete. As Al has pointed out on his website, they do not want a reduction in the demand for oil. This would mean a reduction in oil company profits. If the consumer used half or less of the oil now being used, government tax revenues would be reduced accordingly. If the Gen III were to become available the public interest in fuel economy and clean air would be served and Allen Caggiano would become rich beyond wild imaginings, but the oil/energy cartel and its partner in government would suffer. Therefore, the Big Boys will continue to

do all that they can to stop Al and his FIVS and to keep the public ignorant of any technology they do not themselves control. If they don't control it, and if you don't buy it from them, then it doesn't work, or it's a fraud.

The "FIVS Gen III International" enterprise has been successfully suppressed. Al's fight to manufacture and distribute his invention and enjoy the great wealth it would have given him is over. The Big Boys have broken his bank, and his health. The struggle has nearly destroyed him. The money would have been nice, but it never was the money that kept him going. He is now donating his work of a life time to the American people. The Big Boys can harass, intimidate, and attempt to kill one man and his American Dream, but can they do the same to many thousands of Americans and others around the world? Al now gives away his "FIVS Gen III" plans free on his web site.

Al will allow his patent application for the Gen III to expire. He can no longer afford the large investment required for a patent here and in other countries. His main concern now is to prevent the FIVS from being patented by anyone and to keep the device "open source", so to speak, so that it cannot come under the control of the Big Boys and will remain freely available to the public. Though Al will not profit from his invention through licensing fees or royalties, there is considerable satisfaction for him in knowing that the Big Boys have not and will not ultimately win this game and destroy the work of a lifetime.

-----

So, do you still think that no bravery is involved if you decide to manufacture and sell a high-mileage carburettor? Or do you think that high-mileage carburettors don't actually work? You are, of course, entitled to your own opinion.

Further information on free-energy topics can be found at [www.geocities.com/pjk\\_over\\_unity](http://www.geocities.com/pjk_over_unity)